



## Ag Belting & Lacing, Lacing Tools

REVISED 07/22



# PARTS CATALOGUE

## SECTION 10



*Westward has the part!*

## INDEX

|  |       |                                    |        |
|--|-------|------------------------------------|--------|
| Alligator Rivet Lacing .....                           | 31-33 | Harvest Header Belts .....         | 20-23  |
| Baler Belt Installation Instruction .....              | 12    | Inverter Belts .....               | 14     |
| Baler Starter Flaps .....                              | 13    | Lacers .....                       | 51-56  |
| Bale Thrower Belt .....                                | 13    | Lacing                             |        |
| Belt Sets, John Deere .....                            | 7     | Alligator Rivet .....              | 31-33  |
| Belt, Skiver .....                                     | 56-57 | Clipper .....                      | 27-28  |
| Belts  |       | Clipper Unibar .....               | 28     |
| Bale Thrower Belts .....                               | 13    | Connecting Pins .....              | 29-30  |
| Baler Belts .....                                      | 1-11  | Flexco Bolt Hinged .....           | 43-44  |
| Bean Windrower .....                                   | 14    | Flexco Bolt Solid Plate .....      | 49-50  |
| Bulk Baler Belting .....                               | 10-11 | Flexco SR Scalloped Edge .....     | 45-48  |
| Combine Pick-Up Belts .....                            | 16-17 | Mato .....                         | 6, 34  |
| Windrow Invertor Belts .....                           | 14    | Ready Set™ .....                   | 34-38  |
| Bulk Baler Belting .....                               | 10-11 | Titan .....                        | 33     |
| Clipper Lacing .....                                   | 27-28 | Tools .....                        | 51-57  |
| Combine Pick-Up Belts .....                            | 16-17 | Transmission Belt Lacing .....     | 42     |
| Combine Harvest Header Belts .....                     | 20-23 | Pick-Up Belts .....                | 16-17  |
| Conveyor Belts .....                                   | 15    | Pick-Up Belt Teeth and Bolts ..... | 18     |
| Cut to Length Belting .....                            | 2-9   | Precut Drapers .....               | 22     |
| Cutting & Installation Instructions - Bulk Rolls ..... | 24    | Ready Set™ Tool .....              | 35, 55 |
| Diamond Top Belt Sets .....                            | 7     | Starter Flaps .....                | 13     |
| Fastener Size Selection Chart .....                    | 26    | Teeth .....                        | 18     |
| Fasteners .....  | 27-50 | Tub Grinder Belts .....            | 25     |



## BALER BELTING

WCCO tests and records the belt property values for industry standard belt constructions to establish baseline performance data that our designs need to exceed. End-users benefit with increased belt life and uptime.

**FABRIC** - It's the most critical belt component. Fabric impacts a baler belt's tensile strength, tear resistance, puncture resistance, hook retention, and more. WCCO uses the highest quality fabrics to products products you can trust in the field.

**RUBBER** - The field performance of WCCO products can also be attributed to a high quality rubber compound. Its formula was designed and tested to withstand highly abrasive conditions and environmental resistance to safeguard against wear.



**TT - Texture Top**  
Light-textured fabric impression used for multiple applications

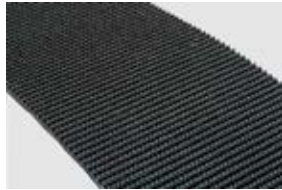

**RT - Rough Top**  
Texture Height - 0.198 in (5.0 mm)  
Heavy-textured fabric impression used for multiple applications.



**MRT - Mini Rough Top**  
Medium-textured fabric impression used for multiple applications.

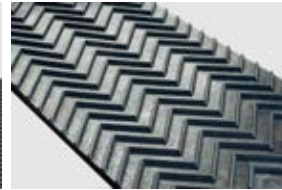

**CT - Chevron Top**  
Pattern Height 0.125 in (3.8 mm)

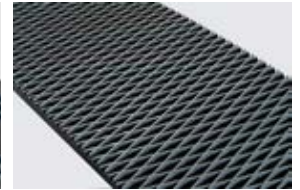

**DT - Diamond Top**  
Pattern Height - 0.158 in (4.0 mm)

## BALER BELT LACING



### CLIPPER (CLIP)

A low-profile splice with a double-staggered grip pattern. WCCO uses the RHTX (rectangular high tensile) Clipper which is the strongest hook style fastener. It features "Xtra" wire mass for an enhanced splice life, superior strength, and resistance to wear. It's also an economical option.



### ALLIGATOR RIVET (AR)

Another popular lacing style for baler belting, the fasteners are installed in one simple procedure with self-setting rivet technology using a portable fixture and a hammer. The rivets are driven through the fastener plates and the belt, passing between the carcass fibers.



### HEAVY PLATE/MATO (HP)

The U-Series and H-Series were designed to compete with Alligator Rivet. The U-Series fits belts from 4-7mm thick and is used for high volume lacing. The H-Series is for belts from 5-7mm thick and is a more economical option with an installation tool that allows for easier splice repair in the field. H-Series tools can only install H-Series fasteners.



### TITAN 05 (TITAN)

Made of stainless steel, Titan fasteners are suitable for extreme crop conditions such as silage or high density hay baling. A disadvantage of this type is the difficulty to install as it is not user-friendly. As such, WCCO is seeing that it's slowly being replaced by the Alligator Rivet.

## BALER BELTING (ROUGH TOP WITH CLIPPER LACING & PINS UNLESS OTHERWISE NOTED)

### TO FIT ALLIS-CHALMERS

| MODELS     | OEM NO. | DESCRIPTION | SIZE        | 2 PLY TEXTURE TOP BELTS WITH CLIPPER LACING |             |          | 3 PLY BALER BELTS WITH CLIPPER LACING unless noted otherwise |          |          |
|------------|---------|-------------|-------------|---|-------------|----------|--|----------|----------|
|            |         |             |             | BELTS/BALER                                 | PART NO.    | SHIP WT. | FINISH & LACING  | PART NO. | SHIP WT. |
| Roto-Baler | 509672  | Upper       | 5.5" x 72"  | 6   | BEL20-AC072 | 3        |  |          |          |
|            | 509673  | Lower       | 5.5" x 102" | 6   | BEL20-AC102 | 5        |  |          |          |

### TO FIT CASE IH

| MODELS                               | OEM NO.  | DESCRIPTION | SIZE        | 2 PLY TEXTURE TOP BELTS WITH CLIPPER LACING |             |          | 3 PLY BALER BELTS WITH CLIPPER LACING unless noted otherwise |             |          |
|--------------------------------------|----------|-------------|-------------|---|-------------|----------|--|-------------|----------|
|                                      |          |             |             | BELTS/BALER                                 | PART NO.    | SHIP WT. | FINISH & LACING  | PART NO.    | SHIP WT. |
| 3440                                 |          | Upper       | 11 x 73.25  | 12  | BEL20-UV173 | 6        | Texture Top  |             | 8        |
|                                      |          | Lower       | 11 x 103.5  | 4   | BEL20-UV103 | 19       | Texture Top  |             | 22       |
| 3450                                 | Newer    | Upper       | 11 x 73.25  | 15  | BEL20-UV173 | 6        | Texture Top  |             | 8        |
|                                      | All      | Lower       | 11 x 103.5  | 5   | BEL20-UV103 | 19       | Texture Top  |             | 22       |
| 3640                                 |          | Upper       | 11 x 73.25  | 20  | BEL20-UV173 | 6        | Texture Top  |             | 8        |
|                                      |          | Lower       | 11 x 121.25 | 4   | BEL20-UV121 | 10       | Texture Top  |             | 13       |
| 3650                                 | Early    | Upper       | 11 x 73.25  | 20  | BEL20-UV173 | 6        | Texture Top  |             | 6        |
|                                      | Newer    | Upper       | 11 x 73.25  | 25  | BEL20-UV173 | 6        | Texture Top  |             | 8        |
|                                      | All      | Lower       | 11 x 121.25 | 5   | BEL20-UV121 | 10       | Texture Top  |             | 13       |
| 8440                                 | 828178   | Upper       | 4 x 452     | 9   | BEL20-HS452 | 13       | Chevron  | BEL1002854  | 17       |
| 8450                                 |          | Upper       | 7 x 570     | 4   |             |          | Chevron with Titan   | BEL20-IH573 | 36       |
| 8455                                 |          | Upper       | 7 x 562.5   | 6   | BEL20-IH562 | 29       | Chevron  | BEL1002861  | 36       |
|                                      |          | Upper       | 7 x 562.5   | 6   |             |          | Chevron w/Titan  | BEL20-IH563 | 36       |
|                                      |          | Upper       | 7 x 562.5   | 6   |             |          | Chevron w/AR   | BEL1004105  | 36       |
| 8460                                 | Earlier  | Upper       | 7 x 570     | 6   |             |          | Chevron w/Titan  | BEL20-IH573 | 36       |
|                                      | Newer    | Upper       | 7 x 562.5   | 8   | BEL20-IH562 | 29       | Chevron  | BEL1002861  | 36       |
|                                      | Newer    | Upper       | 7 x 562.5   | 8   |             |          | Chevron w/Titan  | BEL20-IH563 | 36       |
|                                      | Optional | Upper       | 7 x 562.5   | 8   |             |          | Chevron w/AR   | BEL1004105  | 36       |
| 8465                                 |          | Upper       | 7 x 562.5   | 8   | BEL20-IH562 | 29       | Chevron  | BEL1002861  | 36       |
|                                      | Optional | Upper       | 7 x 562.5   | 8   |             |          | Chevron w/Titan  | BEL20-IH563 | 36       |
|                                      | Optional | Upper       | 7 x 562.5   | 8   |             |          | Chevron w/AR   | BEL1004105  | 36       |
| 8480                                 |          | Upper       | 11 x 73.25  | 25  | BEL20-UV173 | 6        | Texture Top  |             | 8        |
|                                      |          | Lower       | 11 x 121.25 | 5   | BEL20-UV121 | 10       | Texture Top  |             | 13       |
| RBX461<br>RBX462<br>RBX463<br>RBX464 | Optional | Upper       | 7 x 420.5   | 6   |             |          | Chevron  | BEL1003789  | 26       |
| RBX561<br>RBX562<br>RBX563<br>RBX564 | Optional | Upper       | 7 x 420.5   | 8   |             |          | Chevron  | BEL1003789  | 26       |
| RS561                                |          | Upper       | 7 x 547     | 8   |             |          | Chevron w/Titan  | BEL20-HS547 | 46       |
| RB455                                |          | Upper       | 7x343       | 6   |             |          | Mini Rough Top   | BEL1002866  | 22       |
| RB455A                               |          | Upper       | 7x343       | 5   |             |          | Mini Rough Top   | BEL1002866  | 22       |

**BALER BELTING (ROUGH TOP WITH CLIPPER LACING & PINS UNLESS OTHERWISE NOTED)**
**TO FIT CASE IH (Cont'd)**

| MODELS | OEM NO. | DESCRIPTION | SIZE    | 2 PLY TEXTURE TOP BELTS<br>WITH CLIPPER LACING |          |          | 3 PLY BALER BELTS WITH CLIPPER LACING<br>unless noted otherwise |            |          |
|--------|---------|-------------|---------|--|----------|----------|---|------------|----------|
|        |         |             |         | BELTS/<br>BALER                                | PART NO. | SHIP WT. | FINISH & LACING   | PART NO.   | SHIP WT. |
| RB465  |         | Upper       | 7x420.5 | 6  |          |          | Mini Rough Top  | BEL1002462 | 27       |
|        |         | Upper       | 7x420.5 | 6  |          |          | .285 MRT w/HP   | BEL1013205 | 32       |
| RB565  |         | Upper       | 7x420.5 | 8  |          |          | Mini Rough Top  | BEL1002462 | 27       |
|        |         | Upper       | 7x420.5 | 8  |          |          | .285 MRT w/HP   | BEL1013205 | 32       |

**TO FIT FORD/NEW HOLLAND**

| MODELS  | OEM NO.   | DESCRIPTION | SIZE      | 2 PLY TEXTURE TOP BELTS<br>WITH CLIPPER LACING |             |          | 3 PLY BALER BELTS WITH CLIPPER LACING<br>unless noted otherwise |            |          |
|---|-----------|-------------|-----------|--|-------------|----------|---|------------|----------|
|   |           |             |           | BELTS/<br>BALER                                | PART NO.    | SHIP WT. | FINISH & LACING   | PART NO.   | SHIP WT. |
| 551   | GH-066548 | Upper       | 5 x 450   | 3  | BEL20-UV451 | 16       | Texture Top   |            | 22       |
| 630-634                                       |           | Upper       | 7 x 272.5 | 6  | BEL20-UV272 | 14       | Mini Rough Top  |            | 18       |
| 638   |           | Upper       | 7 x 272.5 | 6  | BEL20-UV272 | 14       | Mini Rough Top  |            | 18       |
| 640   | 9843314   | Upper       | 7 x 343   | 6  | BEL20-UV343 | 18       | Mini Rough Top  | BEL1002866 | 22       |
| 644, 648<br>Silage Special                    | 86642911  | Upper       | 7 x 343   | 6  | BEL20-UV343 | 18       | Mini Rough Top  | BEL1002866 | 22       |
| 650-654                                       | 86642412  | Upper       | 7 x 420.5 | 6  | BEL20-UV420 | 21       | Mini Rough Top  | BEL1002462 | 27       |
|   |           | Upper       | 7x420.5   | 6  |             |          | .285 MRT w/HP   | BEL1013205 | 32       |
| 660   | 86642412  | Upper       | 7 x 420.5 | 8  | BEL20-UV420 | 21       | Mini Rough Top  | BEL1002462 | 27       |
| 658<br>(all versions)                         |           | Upper       | 7 x 420.5 | 6  | BEL20-UV420 | 21       | Mini Rough Top  | BEL1002462 | 27       |
|   |           | Upper       | 7x420.5   | 6  |             |          | .285 MRT w/HP   | BEL1013205 | 32       |
| 664, 688                                      |           | Upper       | 7 x 420.5 | 8  | BEL20-UV420 | 21       | Mini Rough Top  | BEL1002462 | 27       |
|   |           | Upper       | 7x420.5   | 8  |             |          | .285 MRT w/HP   | BEL1013205 | 32       |
| 668   |           | Upper       | 7 x 420.5 | 8  | BEL20-UV420 | 21       | Mini Rough Top  | BEL1002462 | 27       |
|   |           | Upper       | 7x420.5   | 8  |             |          | .285 MRT w/HP   | BEL1013205 | 32       |
| 678   |           | Upper       | 7 x 343   | 8  | BEL20-UV343 | 18       | Mini Rough Top  | BEL1002866 | 22       |
| Roll-Belt 450<br>Utility                      |           | Upper       | 7x343     | 5  |             |          | .230 MRT  | BEL1002866 | 22       |
| Roll-Belt 450                                 |           | Upper       | 7x343     | 6  |             |          | .230 MRT  | BEL1002866 | 22       |
| Roll-Belt 460                                 |           | Upper       | 7x420.5   | 6  |             |          | .230 MRT  | BEL1002462 | 27       |
|   |           | Upper       | 7x420.5   | 6  |             |          | .285 MRT w/HP   | BEL1013205 | 32       |
| Roll-Belt 550<br>Roll-Belt 560                |           | Upper       | 7x420.5   | 8  |             |          | .230 MRT  | BEL1002462 | 27       |
|   |           | Upper       | 7x420.5   | 8  |             |          | .285 MRT w/HP   | BEL1013205 | 32       |
| BR730<br>BR730 High<br>Moisture<br>BR7050     | 86625675  | Upper       | 7 x 272.5 | 6  | BEL20-UV272 | 16       | Mini Rough Top  |            | 18       |
| BR740   | 86642411  | Upper       | 7 x 343   | 6  | BEL20-UV343 | 16       | Mini Rough Top  | BEL1002866 | 22       |
| BR740<br>BR760<br>Silage<br>Special<br>BR7060 | 86642411  | Upper       | 7 x 343   | 6  | BEL20-UV343 | 16       | Mini Rough Top  | BEL1002866 | 22       |

## BALER BELTING (ROUGH TOP WITH CLIPPER LACING & PINS UNLESS OTHERWISE NOTED)

### TO FIT FORD/NEW HOLLAND (Cont'd)

| MODELS                               | OEM NO.  | DESCRIPTION    | SIZE      | 2 PLY TEXTURE TOP BELTS WITH CLIPPER LACING |             |          | 3 PLY BALER BELTS WITH CLIPPER LACING unless noted otherwise |            |          |
|--------------------------------------|----------|----------------|-----------|---|-------------|----------|--|------------|----------|
|                                      |          |                |           | BELTS/BALER                                 | PART NO.    | SHIP WT. | FINISH & LACING  | PART NO.   | SHIP WT. |
| BR560<br>BR750 All Purpose<br>BR7070 | 86642412 | Upper          | 7 x 420.5 | 6   | BEL20-UV420 | 21       | Mini Rough Top   | BEL1002462 | 27       |
|                                      |          | Upper          | 7 x 420.5 | 6   |             |          | .285 MRT w/HP  | BEL1013205 | 32       |
| BR770<br>BR7060<br>BR7080            | 86642411 | Upper          | 7 x 343   | 8   | BEL20-UV343 | 16       | Mini Rough Top   | BEL1002866 | 22       |
| BR780<br>BR790<br>BR7090             | 9828294  | Upper          | 7 x 420.5 | 8   | BEL20-UV420 | 21       | Mini Rough Top   | BEL1002462 | 27       |
|                                      |          | Optional Upper | 7 x 420.5 | 8   |             |          | .285 MRT w/HP  | BEL1013205 | 32       |

### TO FIT FORD/NEW HOLLAND - Optional .315" Construction

| MODELS   | OEM NO. | DESCRIPTION | SIZE      | 2 PLY TEXTURE TOP BELTS WITH CLIPPER LACING |          |          | 3 PLY BALER BELTS WITH CLIPPER LACING unless noted otherwise |              |          |
|--|---------|-------------|-----------|---|----------|----------|--|--------------|----------|
|  |         |             |           | BELTS/BALER                                 | PART NO. | SHIP WT. | FINISH & LACING  | PART NO.     | SHIP WT. |
| <b>New Holland Optional .315" Construction</b> |         |             |           |   |          |          |  |              |          |
| 650-654  |         | Upper       | 7 x 420.5 | 6   |          |          | Mini Rough Top   | BEL20-NH420  | 34       |
| 658 (all versions)                             |         | Upper       | 7 x 420.5 | 6   |          |          | Mini Rough Top   | BEL20-NH420  | 34       |
|  |         | Upper       | 7 x 420.5 | 8   |          |          | Mini Rough Top w/AR  | BEL1003770   | 34       |
| 660-664  |         | Upper       | 7 x 420.5 | 8   |          |          | Mini Rough Top   | BEL20-NH420  | 34       |
|  |         | Upper       | 7 x 420.5 | 8   |          |          | Mini Rough Top w/AR  | BEL1003770   | 34       |
| 668  |         | Upper       | 7 x 420.5 | 8   |          |          | Mini Rough Top   | BEL20-NH420  | 34       |
|  |         | Upper       | 7 x 420.5 | 8   |          |          | Mini Rough Top w/AR  | BEL1003770   | 34       |
| 688  |         | Upper       | 7 x 420.5 | 8   |          |          | Mini Rough Top   | BEL 20-NH420 | 34       |
|  |         | Upper       | 7 x 420.5 | 8   |          |          | Mini Rough Top w/AR  | BEL1003770   | 34       |
| BR560<br>BR750<br>BR750<br>All Purpose         |         | Upper       | 7 x 420.5 | 6   |          |          | Mini Rough Top   | BEL20-NH420  | 34       |
|  |         | Upper       | 7 x 420.5 | 8   |          |          | Mini Rough Top w/AR  | BEL1003770   | 34       |
| BR7070 Roll Belt 460                           |         | Upper       | 7 x 420.5 | 6   |          |          | Mini Rough Top   | BEL20-NH420  | 34       |
|  |         | Upper       | 7 x 420.5 | 6   |          |          | Mini Rough Top w/AR  | BEL1003770   | 34       |
| BR780, BR7090<br>Roll Belt 550, 560            |         | Upper       | 7 x 420.5 | 8   |          |          | Mini Rough Top   | BEL20-NH420  | 34       |
|  |         | Upper       | 7 x 420.5 | 8   |          |          | Mini Rough Top w/AR  | BEL1003770   | 34       |

### TO FIT GEHL

| MODELS             | OEM NO. | DESCRIPTION | SIZE      | 2 PLY TEXTURE TOP BELTS WITH CLIPPER LACING |             |          | 3 PLY BALER BELTS WITH CLIPPER LACING unless noted otherwise |          |          |
|--------------------|---------|-------------|-----------|---|-------------|----------|--|----------|----------|
|                    |         |             |           | BELTS/BALER                                 | PART NO.    | SHIP WT. | FINISH & LACING  | PART NO. | SHIP WT. |
| 1400               | 66548   | Upper       | 5 x 450   | 3   | BEL20-UV451 | 16       | Texture Top  |          | 22       |
| 1475<br>1375, 1370 |         | Upper       | 6 x 469   | 6   | BEL20-GH463 | 20       | Chevron  |          | 28       |
| 1865, 1870         |         | Upper       | 6 x 545.5 | 8   | BEL20-GH545 | 23       | Texture Top  |          | 29       |

**BALER BELTING (ROUGH TOP WITH CLIPPER LACING & PINS UNLESS OTHERWISE NOTED)**

**TO FIT HESSTON**

| MODELS                           | OEM NO.                    | DESCRIPTION    | SIZE        | 2 PLY TEXTURE TOP BELTS WITH CLIPPER LACING |             |          | 3 PLY BALER BELTS WITH CLIPPER LACING unless noted otherwise |             |          |
|----------------------------------|----------------------------|----------------|-------------|---|-------------|----------|--|-------------|----------|
|                                  |                            |                |             | BELTS/BALER                                 | PART NO.    | SHIP WT. | FINISH & LACING  | PART NO.    | SHIP WT. |
| 514, 814                         |                            | Upper          | 11 x 73.25  | 25  | BEL20-UV173 | 6        | Texture Top  |             | 8        |
|                                  |                            | Lower          | 11 x 121.25 | 5   | BEL20-UV121 | 10       | Texture Top  |             | 13       |
| 550                              | 700-713-630                | Optional Upper | 7 x 750     | 4   |             |          | Chevron w/Titan  | BEL20-IH573 | 36       |
| 555                              | 700-709-999                | Upper          | 7 x 562.5   | 6   | BEL20-IH562 | 29       | Chevron  | BEL1002861  | 36       |
|                                  | 700-713-617                | Upper          | 7 x 562.5   | 6   |             |          | Chevron w/Titan  | BEL20-IH563 | 36       |
|                                  | 700-713-617                | Optional Upper | 7 x 562.5   | 6   |             |          | Chevron w/AR   | BEL1004105  | 36       |
| 560<br>Serial No. 1965 or Higher | 700-709-999                | Upper          | 7 x 562.5   | 8   | BEL20-IH562 | 29       | Chevron  | BEL1002861  | 36       |
|                                  | 700-713-617                | Optional Upper | 7 x 562.5   | 8   |             |          | Chevron w/Titan  | BEL20-IH563 | 36       |
|                                  | 700-713-617                | Optional Upper | 7 x 562.5   | 8   |             |          | Chevron w/AR   | BEL1004105  | 36       |
| 560<br>Serial No. 0220-1964      | 700-707-162<br>700-731-617 | Optional Upper | 7 x 570     | 6   |             |          | Chevron w/Titan  | BEL20-IH573 | 36       |
| 565 (Newer Models)               |                            | Upper          | 7 x 562.5   | 6   | BEL20-IH562 | 29       | Chevron  | BEL1002861  | 36       |
|                                  |                            | Upper          | 7 x 562.5   | 6   |             |          | Chevron w/Titan  | BEL20-IH563 | 36       |
|                                  |                            | Optional Upper | 7 x 562.5   | 8   |             |          | Chevron w/AR   | BEL1004105  | 36       |
| 565A                             | 700728090                  | Upper          | 7 x 562.5   | 8   |             |          | MRT w/AR   | BEL1003887  |          |
| 856, 856A<br>956, 956A           | 700-717-717<br>700-728-088 | Upper          | 7 x 547     | 8   |             |          | Chevron w/Titan  | BEL20-HS547 | 36       |
| 5500 &<br>5510                   | 828178                     | Upper          | 4 x 452     | 9   | BEL20-HS452 | 13       | Chevron  | BEL1002854  | 17       |
| 5540                             | 828335                     | Upper          | 5.3 x 470   | 6   | BEL20-HS470 | 18       | Chevron  |             | 30       |
| 5545                             |                            | Upper          | 5.3 x 465   | 6   |             | 15       | Chevron  | BEL20-HS466 | 20       |
| 5580                             | 828335                     | Upper          | 5.3 x 470   | 8   | BEL20-HS470 | 18       | Chevron  |             | 30       |
| 5585                             |                            | Upper          | 5.3 x 465   | 8   |             | 15       | Chevron  | BEL20-HS466 | 20       |
| 5800                             | 782991                     | Upper          | 4 x 480     | 9   | BEL20-HS480 | 14       | Texture Top  | BEL1000363  | 18       |

\* Requires Hesston Modification Kit



**TT - Texture Top**

Light-textured fabric impression used for multiple applications



**RT - Rough Top**

Texture Height - 0.198 in (5.0 mm)  
Heavy-textured fabric impression used for multiple applications.



**MRT - Mini Rough Top**

Medium-textured fabric impression used for multiple applications.

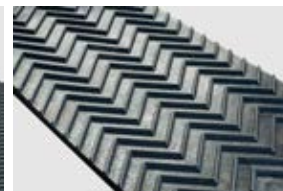

**CT - Chevron Top**

Pattern Height 0.125 in (3.8 mm)



**DT - Diamond Top**

Pattern Height - 0.158 in (4.0 mm)

## BALER BELTING (ROUGH TOP WITH CLIPPER LACING & PINS UNLESS OTHERWISE NOTED)

### TO FIT JOHN DEERE

| MODELS   | OEM NO. | DESCRIPTION | SIZE       | 2 PLY TEXTURE TOP BELTS WITH CLIPPER LACING |             |          | 3 PLY BALER BELTS WITH CLIPPER LACING unless noted otherwise |              |          |
|--|---------|-------------|------------|---|-------------|----------|--|--------------|----------|
|  |         |             |            | BELTS/BALER                                 | PART NO.    | SHIP WT. | FINISH & LACING  | PART NO.     | SHIP WT. |
| 510  | AE35484 | Upper       | 4 x 484    | 9   | BEL20-JD484 | 14       | Texture Top  |              | 18       |
| 330, 335, 446, 447, 448, 449, 570, 572, 842  | DC22173 | Upper       | 7 x 402.75 | 2   |             |          | Diamond Top  | BEL20-JD402R | 38       |
|  | DC22174 | Upper       | 7 x 410.25 | 4   |             |          | Diamond Top  | BEL20-JD410R | 38       |
| 375, 546, 547, 548   | DC22173 | Upper       | 7 x 402.75 | 4   |             |          | Diamond Top  | BEL20-JD402R | 38       |
|  | DC22174 | Upper       | 7 x 410.25 | 4   |             |          | Diamond Top  | BEL20-JD410R | 38       |
| 430, 435, 466, 467, 590, 592, 862  | AE40797 | Upper       | 7 x 525    | 2   |             |          | Diamond Top  | BEL20-JD525R | 49       |
|  | AE40798 | Upper       | 7 x 531    | 4   |             |          | Diamond Top  | BEL20-JD531R | 49       |
|  | AE53295 | Upper       | 7 x 525    | 2   |             |          | DT & HP  | BEL20-JD525H | 49       |
|  | AE53296 | Upper       | 7 x 531    | 4   |             |          | DT & HP  | BEL20-JD531H | 49       |
|  |         | Upper       | 7 x 525    | 2   |             |          | DT & AR  | BEL1003288   | 49       |
|  | Upper   | 7 x 531     | 4          |   |             | DT & AR  | BEL1003287   | 49           |          |
| 468, 468SS, 469, 460M, 460M Silage, 460M Mega Wide, 460R, 460R Mega Wide                   |         | Upper       | 7x524      | 2   |             |          | DT & AR  | BEL1012435   | 49       |
|  |         | Upper       | 7x529.5    | 4   |             |          | DT & AR  | BEL1012436   | 49       |
| 530, 535, 536, 566, 567  | AE40797 | Upper       | 7 x 525    | 4   |             |          | Diamond Top  | BEL20-JD525R | 49       |
|  | AE40798 | Upper       | 7 x 531    | 4   |             |          | Diamond Top  | BEL20-JD531R | 49       |
|  | AE53295 | Upper       | 7 x 525    | 4   |             |          | DT & HP  | BEL20-JD525H | 49       |
|  | AE53296 | Upper       | 7 x 531    | 4   |             |          | DT & HP  | BEL20-JD531H | 49       |
|  |         | Upper       | 7 x 525    | 4   |             |          | DT & AR  | BEL1003288   | 49       |
|  | Upper   | 7 x 531     | 4          |   |             | DT & AR  | BEL1003287   | 49           |          |
| 568, 569, 569 Silage, 569 Premium, 560M, 560M Silage, 560M Mega Wide, 560R, 560R Mega Wide |         | Upper       | 7x524      | 4   |             |          | DT & AR  | BEL1012435   | 49       |
|  |         | Upper       | 7x529.5    | 4   |             |          | DT & AR  | BEL1012436   | 49       |

\*Note: Recommend using only endless belts for the 410 & 510 lower belts.

## HEAVY PLATE (MATO) STYLE LACING AND ACCESSORIES

### MATO "U" TOOLS AND ACCESSORIES

| PART NUMBER  | DESCRIPTION   |
|--------------|---|
| LAC411295862 | U24BS Heavy Plate 14 Segment Used for 7" John Deere Baler Belts |
| LAC411295807 | MATO Hex Shank Punch for Air Hammer                             |
| LAC411295825 | Hand Punch  |
| LAC411295827 | 18mm Belt Skiver  |
| LCR411295869 | 07 U20 Prof-14 Used for 7" John Deere Baler Belts               |
| LCR411295828 | Replacement Blades for Belt Skiver (5/pkg)                      |

### MATO "H" TOOLS AND ACCESSORIES

| PARTNUMBER   | DESCRIPTION   |
|--------------|---|
| LCR411296961 | 7" H24 Profi Installation Field Tool Continuous Lacing Capabilities Wider than 7" |
| LAC411156069 | H24BS 14 Segment Used for 7" John Deere Baler Belts                               |
| LAC411296963 | 7" H24 Eco Field Tool   |

| PARTNUMBER | DESCRIPTION   |
|------------|---|
| BEL1701433 | Pin Notched Spring Steel 6.5" (for John Deere 7" belts) |



**BALER BELTING (ROUGH TOP WITH CLIPPER LACING & PINS UNLESS OTHERWISE NOTED)**
**DIAMOND TOP BELT SETS TO FIT JOHN DEERE BALERS**

| MODELS             | PART NO.    | DESCRIPTION                                       | 3 PLY DIAMOND TOP | LACING         |
|--------------------|-------------|---|-------------------|----------------|
| 530, 535, 566, 567 | BEL20-JDBSR | Consists of 4 - BEL20-JD525R and 4 - BEL20-JD531R | 3 ply DT          | Clipper Lacing |
| 530, 535, 566, 567 | BEL20-JDBSH | Consists of 4 - BEL20-JD525H and 4 - BEL20-JD531H | 3 ply DT          | Heavy Plate    |

Precut connecting pin for Diamond Top Belts with Clipper Lacing Part No: LACBUL4.5 Pin 7" in length.

**TO FIT MASSEY FERGUSON**

| MODELS                                   | OEM NO.      | DESCRIPTION    | SIZE      | 2 PLY TEXTURE TOP BELTS WITH CLIPPER LACING |             |          | 3 PLY BALER BELTS WITH CLIPPER LACING unless noted otherwise |             |          |
|--|--------------|----------------|-----------|---|-------------|----------|--|-------------|----------|
|  |              |                |           | BELTS/BALER                                 | PART NO.    | SHIP WT. | FINISH & LACING  | PART NO.    | SHIP WT. |
| 144                                      | 700709999    | Upper          | 7 x 562.5 | 6   | BEL20-IH562 | 29       | Chevron  | BEL1002861  | 36       |
|  |              | Upper          | 7 x 562.5 | 6   |             |          | Chevron w/ Titan   | BEL20-IH563 | 36       |
|  | 700718617    | Upper          | 7 x 562.5 | 6   |             |          | MRT w/AR   | BEL1003887  | 34       |
| 146                                      | 700709999    | Upper          | 7 x 562.5 | 8   | BEL20-IH562 | 29       | Chevron  | BEL1002861  | 36       |
|  |              | Upper          | 7 x 562.5 | 8   |             |          | Chevron w/ Titan   | BEL20-IH563 | 36       |
|  | 700718617    | Upper          | 7 x 562.5 | 8   |             |          | MRT w/AR   | BEL1003887  | 34       |
| 450                                      |              | Upper          | 9 x 388   |   |             | 28       | TT   | BEL1000694  | 30       |
| 560                                      | 1045-352-M92 | Upper          | 4 x 440   | 9   | BEL20-UV440 | 13       | TT   |             | 17       |
| 645                                      |              | Upper          | 6.5 x 528 | 6   | BEL20-VR528 | 26       | TT   | BEL1000395  | 31       |
| 656                                      |              | Upper          | 6.5 x 528 | 8   | BEL20-VR528 | 26       | TT   | BEL1000395  | 31       |
| 835                                      |              | Upper          | 6 x 545.5 | 8   | BEL20-GH545 | 24       | Chevron  |             | 30       |
| 1500<br>1560 (optional inside)<br>& 1565 | 1053-386-M91 | Upper          | 4 x 512   | 6   | BEL20-UV512 | 14       | TT   | BEL1000679  | 19       |
|  | 1053-387-M91 | Upper/Optional | 10 x 512  | 2   | BEL20-UV513 | 34       | Texture Top  |             | 39       |

**TO FIT MCKEE**

| MODELS     | OEM NO.                  | DESCRIPTION | SIZE      | 2 PLY TEXTURE TOP BELTS WITH CLIPPER LACING |             |          | 3 PLY BALER BELTS WITH CLIPPER LACING unless noted otherwise |          |          |
|------------|--------------------------|-------------|-----------|---|-------------|----------|--|----------|----------|
|            |                          |             |           | BELTS/BALER                                 | PART NO.    | SHIP WT. | FINISH & LACING  | PART NO. | SHIP WT. |
| 875, 878   |                          | Upper       | 7x64.5    | 30  | BEL20-UV065 | 3        | TT   |          |          |
| 1500, 1578 |                          | Upper       | 11x73.25  | 25  | BEL20-UV173 | 6        | TT   |          |          |
|            | 29-626A<br>1701.25.01.01 | Lower       | 11x121.25 | 5   | BEL20-UV121 | 10       | TT   |          |          |



## BALER BELTING (ROUGH TOP WITH CLIPPER LACING & PINS UNLESS OTHERWISE NOTED)

### TO FIT NEW IDEA

| MODELS          | OEM NO.    | DESCRIPTION | SIZE        | 2 PLY TEXTURE TOP BELTS WITH CLIPPER LACING |             |          | 3 PLY BALER BELTS WITH CLIPPER LACING unless noted otherwise |             |          |
|-----------------|------------|-------------|-------------|---|-------------|----------|--|-------------|----------|
|                 |            |             |             | BELTS/BALER                                 | PART NO.    | SHIP WT. | FINISH & LACING  | PART NO.    | SHIP WT. |
| 483, 4844       | Newer      | Upper       | 11 x 73.25  | 12  | BEL20-UV173 | 6        | Texture Top  |             | 8        |
|                 |            | Lower       | 11 x 103.5  | 4   | BEL20-UV103 | 9        | Texture Top  |             | 22       |
| 484, 4845       | Newer      | Upper       | 11 x 73.25  | 15  | BEL20-UV173 | 6        | Texture Top  |             | 8        |
|                 |            | Lower       | 11 x 103.5  | 5   | BEL20-UV103 | 9        | Texture Top  |             | 22       |
| 4855            |            | Upper       | 11x73.25    | 20  | BEL20-UV173 | 6        | Texture Top  |             |          |
|                 |            | Lower       | 11x103.5    | 5   | BEL20-UV103 | 9        | Texture Top  |             |          |
| 483, 484        | 104412     | Lower       | 11 x 103.5  | 5   | BEL20-UV103 | 9        | Texture Top  |             | 22       |
| 485             | 105003     | Upper       | 11 x 73.25  | 20  | BEL20-UV173 | 6        | Texture Top  |             | 8        |
|                 | 104108     | Lower       | 11 x 121.25 | 4   | BEL20-UV121 | 10       | Texture Top  |             | 13       |
| 456, 486 & 4865 | Newer      | Upper       | 11 x 73.25  | 25  | BEL20-UV173 | 6        | Texture Top  |             | 8        |
|                 | 104411-All | Lower       | 11 x 121.25 | 5   | BEL20-UV121 | 10       | Texture Top  |             | 13       |
| 4644            |            | Upper       | 7 x 562.5   | 6   | BEL20-IH562 | 29       | Chevron  | BEL1002861  | 36       |
|                 |            | Upper       | 7 x 562.5   | 6   |             |          | Chevron w/Titan  | BEL20-IH563 | 36       |
| 4665            |            | Upper       | 7 x 562.5   | 8   | BEL20-IH562 | 29       | Chevron  | BEL1002861  | 36       |
|                 |            | Upper       | 7 x 562.5   | 8   |             |          | Chevron w/Titan  | BEL20-IH563 | 36       |
| 4845            | 105003     | Upper       | 11 x 73.25  | 15  | BEL20-UV173 | 6        | Texture Top  |             | 8        |
|                 | 104108     | Lower       | 11 x 121.25 | 5   | BEL20-UV121 | 10       | Texture Top  |             | 13       |
| 6364, 6464      | 700717717  | Upper       | 7 x 547     | 6   |             |          | Chevron w/Titan  | BEL20-HS547 | 36       |
| 6365, 6465      | 700717717  | Upper       | 7 x 547     | 8   |             |          | Chevron w/Titan  | BEL20-HS547 | 36       |

### TO FIT VERMEER

| MODELS                            | OEM NO.  | DESCRIPTION | SIZE      | 2 PLY TEXTURE TOP BELTS WITH CLIPPER LACING |             |          | 3 PLY BALER BELTS WITH CLIPPER LACING unless noted otherwise |            |            |    |
|-----------------------------------|----------|-------------|-----------|---|-------------|----------|--|------------|------------|----|
|                                   |          |             |           | BELTS/BALER                                 | PART NO.    | SHIP WT. | FINISH & LACING  | PART NO.   | SHIP WT.   |    |
| 504C                              |          | Upper       | 9 x 388   |   |             | 28       | Texture Top  | BEL1000694 | 30         |    |
| 604M                              |          | Upper       | 6.8X533   | 3   |             |          | .285 MRT w/AR  | BEL1007457 | 42         |    |
|                                   |          | Upper       | 6.8X522   | 3   |             |          | .285 MRT w/AR  | BEL1007458 | 41         |    |
|                                   |          | Upper       | 7 x 522   | 3   | BEL1005818  |          |  | TT w/AR    |            | 34 |
|                                   |          | Upper       | 7 x 533   | 3   | BEL1005819  |          |  | TT w/AR    | BEL1005808 | 34 |
| 604 Super M                       |          | Upper       | 6.8X533   | 3   |             |          | .285 MRT w/AR  | BEL1007457 | 42         |    |
|                                   |          | Upper       | 6.8X540   | 3   |             |          | .285 MRT w/AR  | BEL1008200 | 43         |    |
| 604N<br>604N Cornstalk<br>Special |          | Upper       | 6.8X540   | 3   |             |          | .285 MRT w/AR  | BEL1008200 | 43         |    |
|                                   |          | Upper       | 6.8X533   | 3   |             |          | .285 MRT w/AR  | BEL1007457 | 42         |    |
| 604XL                             |          | Upper       | 14 x 528  | 2   | BEL20-VR529 | 56       | Texture Top  | BEL1002566 | 70         |    |
|                                   |          | Upper       | 6.5 x 528 | 2   | BEL20-VR528 | 26       | Texture Top  | BEL1000395 | 31         |    |
| 605C                              | F-894    | Upper       | 4 x 440   | 9   | BEL20-UV440 | 13       | Texture Top  |            | 17         |    |
| 605E Original                     |          | Upper       | 4 x 457   | 5   | BEL20-VR457 | 13       | Texture Top  |            | 17         |    |
| 605E Modified                     |          | Upper       | 4 x 440   | 5   | BEL20-UV440 | 13       | Texture Top  |            | 17         |    |
| 605F, 605G,<br>605H               | 1826-001 | Upper       | 4 x 512   | 6   | BEL20-UV512 | 14       | Texture Top  | BEL1000679 | 19         |    |
|                                   | Optional | Upper       | 9 x 512   | 3   | BEL20-UV513 | 32       | Texture Top  |            | 37         |    |
| 604J                              |          | Upper       | 6.5 x 528 | 6   | BEL20-VR528 | 23       | Texture Top  | BEL1000395 | 28         |    |

**BALER BELTING (ROUGH TOP WITH CLIPPER LACING & PINS UNLESS OTHERWISE NOTED)**
**TO FIT VERMEER (Cont'd)**

| MODELS                       | OEM NO. | DESCRIPTION | SIZE      | 2 PLY TEXTURE TOP BELTS WITH CLIPPER LACING |             |          | 3 PLY BALER BELTS WITH CLIPPER LACING unless noted otherwise |            |          |
|------------------------------|---------|-------------|-----------|---|-------------|----------|--|------------|----------|
|                              |         |             |           | BELTS/BALER                                 | PART NO.    | SHIP WT. | FINISH & LACING  | PART NO.   | SHIP WT. |
| 604K, 604L                   |         | Upper       | 6.5 x 528 | 2   | BEL20-VR528 | 26       | Texture Top  | BEL1000395 | 31       |
|                              |         | Upper       | 14 x 528  | 2   | BEL20-VR529 | 56       | Texture Top  | BEL1002566 | 70       |
| 605J, 605 Super J            |         | Upper       | 6.5 x 528 | 8   | BEL20-VR528 | 26       | Texture Top  | BEL1000395 | 31       |
| 605K, 605L                   |         | Upper       | 6.5 x 528 | 2   | BEL20-VR528 | 26       | Texture Top  | BEL1000395 | 31       |
|                              |         | Upper       | 14 x 528  | 3   | BEL20-VR529 | 56       | Texture Top  | BEL1002566 | 70       |
| 605M                         |         | Upper       | 6.8X533   | 4   |             |          | .285 MRT w/AR  | BEL1007457 | 42       |
|                              |         | Upper       | 6.8X522   | 4   |             |          | .285 MRT w/AR  | BEL1007458 | 41       |
|                              |         | Upper       | 7 x 522   | 4   | BEL1005818  |          | TT w/AR  |            | 34       |
|                              |         | Upper       | 7 x 533   | 4   | BEL1005819  |          | TT w/AR  |            | 34       |
| 605 Super M                  |         | Upper       | 6.8X533   | 4   |             |          | .285 MRT w/AR  | BEL1007457 | 42       |
|                              |         | Upper       | 6.8X540   | 4   |             |          | .285 MRT w/AR  | BEL1008200 | 43       |
| 605XL                        |         | Upper       | 14 x 528  | 3   |             | 56       | Texture Top  | BEL1002566 | 70       |
|                              |         | Upper       | 6.5 x 528 | 2   | BEL20-VR528 | 26       | Texture Top  |            | 31       |
| 605N, 605N Cornstalk Special |         | Upper       | 6.8x540   | 4   |             |          | .285 MRT w/AR  | BEL1008200 | 43       |
|                              |         | Upper       | 6.8x533   | 4   |             |          | .285 MRT w/AR  | BEL1007457 | 42       |

**TO FIT VICON**

| MODELS | OEM NO. | DESCRIPTION | SIZE        | 2 PLY TEXTURE TOP BELTS WITH CLIPPER LACING |             |          | 3 PLY BALER BELTS WITH CLIPPER LACING unless noted otherwise |            |          |
|--------|---------|-------------|-------------|---|-------------|----------|--|------------|----------|
|        |         |             |             | BELTS/BALER                                 | PART NO.    | SHIP WT. | FINISH & LACING  | PART NO.   | SHIP WT. |
| 260    |         | Upper       | 7 x 64.5    | 30  | BEL20-UV065 | 6        | Texture Top  | BEL1001619 | 8        |
| 560    |         | Upper       | 11 x 73.25  | 25  | BEL20-UV173 | 6        | Texture Top  | BEL1000398 | 8        |
|        |         | Lower       | 11 x 121.25 | 5   | BEL20-UV121 | 10       | Texture Top  | BEL1000623 | 13       |
| RP1210 |         | Newer       | 7 x 64.75   | 30  | BEL20-UV065 | 6        | Texture Top  | BEL1001619 | 8        |
| RP1510 |         | Lower       | 11 x 121.25 | 5   | BEL20-UV121 | 10       | Texture Top  | BEL1000623 | 13       |
|        | Newer   | Upper       | 11 x 73.25  | 25  | BEL20-UV173 | 6        | Texture Top  | BEL1000398 | 8        |
|        | Newer   | Lower       | 11 x 121.25 | 5   | BEL20-UV121 | 10       | Texture Top  | BEL1000623 | 13       |
| RP1511 |         | Lower       | 11 x 112    | 5   | BEL20-VI112 | 14       | Texture Top  | BEL1002484 | 17       |



## BULK BALER BELTING

AVAILABLE BY THE FOOT OR ROLL

Westward Parts Bulk Baler Belting is constructed of quality 2 and 3 ply fabric and finished in a field tested rubber textured coating to offer "rough top" aggressiveness in round baler applications.



| ROUGH TOP TEXTURE TOP - 2 PLY |     |                    |                 |                          |
|-------------------------------|-----|--------------------|-----------------|--------------------------|
| WIDTH                         | PLY | TEXTURE TOP/BOTTOM | BULK (PER FOOT) | FULL ROLL (approx. 300') |
| 4"                            | 2   | TT/TB              | BELBEL4RT       | BELBEL4250RT             |
| 4.8"                          | 2   | TT/TB              |                 | BELBEL472250RT           |
| 6"                            | 2   | TT/TB              | BELBEL6RT       | BELBEL6250RT             |
| 7"                            | 2   | TT/TB              | BELBEL7RT       | BELBEL7250RT             |
| 8"                            | 2   | TT/TB              | BELBEL8RT       | BELBEL8250RT             |
| 10"                           | 2   | TT/TB              | BELBEL10RT      | BELBEL10250RT            |
| 11"                           | 2   | TT/TB              | BELBEL11RT      | BELBEL11250RT            |

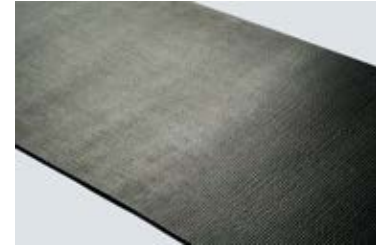

TT - Texture Top

| ROUGH TOP TEXTURE TOP - 3 PLY |     |                    |                 |                          |
|-------------------------------|-----|--------------------|-----------------|--------------------------|
| WIDTH                         | PLY | TEXTURE TOP/BOTTOM | BULK (PER FOOT) | FULL ROLL (approx. 300') |
| 4"                            | 3   | TT/TB              | BELBEL4RT-3     | BELBEL4250RT-3           |
| 4.8"                          | 3   | TT/TB              | BELBEL472RT-3   | BELBEL472250RT-3         |
| 6"                            | 3   | TT/TB              | BELBEL6RT-3     |                          |
| 7"                            | 3   | TT/TB              | BELBEL7RT-3     | BELBEL7250RT-3           |
| 10"                           | 3   | TT/TB              |                 | BELBEL10250RT-3          |
| 11"                           | 3   | TT/TB              | BELBEL11RT-3    | BELBEL11250RT-3          |
| 12"                           | 3   | TT/TB              | BELBEL12RT-3    | BELBEL12250RT-3          |
| 14"                           | 3   | TT/TB              |                 | BELBEL14250RT-3          |



TT - Texture Top

| MINI ROUGH TOP - 3 PLY |     |                    |                 |                          |
|------------------------|-----|--------------------|-----------------|--------------------------|
| WIDTH                  | PLY | TEXTURE TOP/BOTTOM | BULK (PER FOOT) | FULL ROLL (approx. 300') |
| 5.3"                   | 3   | MRT/TB             | BELBEL53MRT-3   |                          |
| 6.5"                   | 3   | MRT/TB             |                 | BELBEL65250MRT-3         |
| 7"                     | 3   | MRT/TB             | BELBEL7MRT-3    | BELBEL7250MRT-3          |
| 11"                    | 3   | MRT/TB             | BELBEL11MRT-3   |                          |

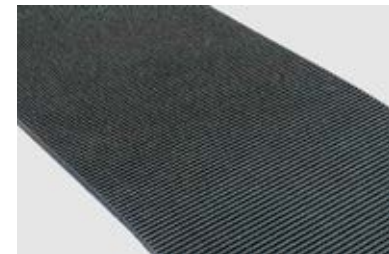

MRT - Mini Rough Top

| ROUGH TOP HERRINGBONE - 3 PLY |     |                    |                 |                          |
|-------------------------------|-----|--------------------|-----------------|--------------------------|
| WIDTH                         | PLY | TEXTURE TOP/BOTTOM | BULK (PER FOOT) | FULL ROLL (approx. 300') |
| 7"                            | 3   | HB                 | BELBEL7HER-3    | BELBEL7250HER-3          |

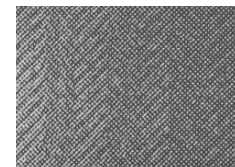

Rough Top Herringbone

**Order Full Rolls (Approx. 300') for Substantial Savings!**

**BULK BALER BELTING**

| DIAMOND TOP - 3 PLY |     |                    |                 |                          |
|---------------------|-----|--------------------|-----------------|--------------------------|
| WIDTH               | PLY | TEXTURE TOP/BOTTOM | BULK (PER FOOT) | FULL ROLL (approx. 300') |
| 7"                  | 3   | DT                 | BELBEL7DIA      | BELBEL7250DIA            |

3 ply Diamond Top is sold in 360 ft. rolls.

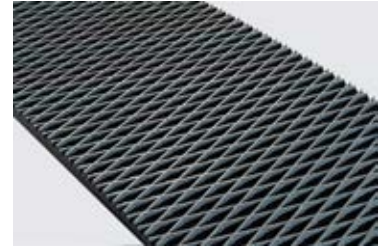

DT - Diamond Top

| CHEVRON TOP - 3 PLY |     |                    |                 |                          |
|---------------------|-----|--------------------|-----------------|--------------------------|
| WIDTH               | PLY | TEXTURE TOP/BOTTOM | BULK (PER FOOT) | FULL ROLL (approx. 300') |
| 6"                  | 3   | CT/TB              | BELBEL6CHE      | BELBEL6250CHE            |
| 7"                  | 3   | CT/TB              | BELBEL7CHE      | BELBEL7250CHE            |

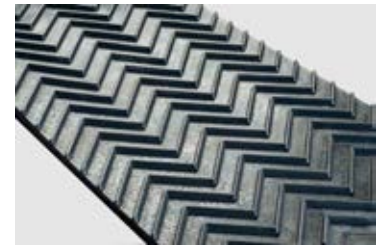

CT - Chevron Top

**BALER BELT LACING**



**CLIPPER (CLIP) - SEE PAGE 28-29**

A low-profile splice with a double-staggered grip pattern. WCCO uses the RHTX (rectangular high tensile) Clipper which is the strongest hook style fastener. It features "Xtra" wire mass for an enhanced splice life, superior strength, and resistance to wear. It's also an economical option.



**ALLIGATOR RIVET (AR) - SEE PAGE 32-34**

Another popular lacing style for baler belting, the fasteners are installed in one simple procedure with self-setting rivet technology using a portable fixture and a hammer. The rivets are driven through the fastener plates and the belt, passing between the carcass fibers.



**HEAVY PLATE/MATO (HP) - SEE PAGE 6 & 34**

The U-Series and H-Series were designed to compete with Alligator Rivet. The U-Series fits belts from 4-7mm thick and is used for high volume lacing. The H-Series is for belts from 5-7mm thick and is a more economical option with an installation tool that allows for easier splice repair in the field. H-Series tools can only install H-Series fasteners.



**TITAN 05 (TITAN) - SEE PAGE 34**

Made of stainless steel, Titan fasteners are suitable for extreme crop conditions such as silage or high density hay baling. A disadvantage of this type is the difficulty to install as it is not user-friendly. As such, WCCO is seeing that it's slowly being replaced by the Alligator Rivet.

## ROUND BALER BELT INSTALLATION - Working from bulk rolls & installing

### GENERAL MAINTENANCE

1. Take up roller adjustment to recommended tension. It is important to check your baler's operating manual for proper tension adjustment. Additionally, please note it is especially important to leave the recommended slack in the belts on Vicon, McKee, New Idea, and corresponding Case IH models. A belt adjusted too tight will have a shorter service life.
2. Occasionally check your belts, belt lacing, and pin during use. Make repairs or replacements as required. Please note the lacing and connecting pin are your belts' weakest points. Proper maintenance is critical to your baler's overall performance.
3. Check your baler thoroughly before starting your next baling season, resize all belts and replace as necessary.

### PREPARATION

1. Always use the same ply construction for all belts. Two-ply and three-ply constructions do not react in the same manner under tension. Using different plied constructions will create an unequal load situation and the baler will not perform properly.
2. Check all bearings for movement without drag or noise. Lubricate or replace as required.
3. Check for bent or broken rollers and replace as required. Free all rollers of rust and foreign material buildup.
4. Eliminate catch points, weld splatters, and sharp metal edges.
5. Replace all worn belts at the same time.
6. Resize all belts, new and old, to equal lengths for maximum load distribution.

## INSTRUCTIONS

### INSTALLATION OF UPPER BELTS

1. Install belt following the "Direction Of Travel" arrow. End with 45-degree corners and the least number of hooks as the trailing end. End with square-cut corners as the leading end.
2. After threading a belt through the machine, pull ends together. Insert the connecting pin through the lacing hooks, making sure the hooks on both ends alternate (leading end should have hooks on both outside edges).
3. After inserting the connecting pin completely, bend approximately 1/2 inch of the straight end at a 90-degree angle to match the other end.

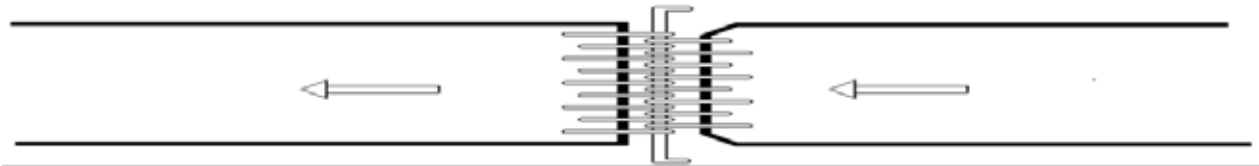

### INSTALLATION OF LOWER PLATFORM APRONS

1. Clean V-guide slots on pulleys. Please note that International Harvester models do not have V-guides.
2. Follow steps one and two from Upper Belts instructions above.
3. If Clipper Lacing is used, insert leader wire attached to the cable, through hooks. Do not jerk on leader wire or it will come off. After cable is in place, remove leader wire, attach retaining nut and crimp it. If Minet Lacing is used, install pin and bend approximately 1/2 inch of straight end at a 90-degree angle.
4. Run baler momentarily to check for proper tracking and adjust as necessary.

### MAINTENANCE OF ENDLESS BELTS

After installing the new belts, decrease the belt tension to about 60-70% of the normal baling tension and run the PTO slowly (less than half normal speed). Watch the belts for tracking so that they don't run up against any belt guides. This will probably take some roller adjustments on the baler. Adjust the rollers according to the baler's Owner's Manual. Slowly increase the PTO speed while watching the belts for tracking. Slowly increase the belt tension to no more than 75% of the normal baling tension. If the belts are running properly you can go to the field for baling. Start baling at a reduced throttle speed to insure proper installation and tracking of the new belts. Do not increase the belt tension for increased bale density until you have run at least 25 bales. This will allow the belts to break-in and conform to your baler. Continue to monitor your belts daily and make adjustments when necessary.

**BALER STARTER FLAPS**

**TO FIT CASE IH**

| BALER MODEL | MANUFACTURER'S PART NO. | DESCRIPTION   | SIZE        | FLAPS/BALER | 3 PLY BALER FLAPS |            | SHIP WT. |
|-------------|-------------------------|---------------|-------------|-------------|-------------------|------------|----------|
|             |                         |               |             |             | FINISH            | PART NO.   |          |
| 8460 - 8465 | 700711997               | Starter Flaps | 3.5 x 61.18 | 4           | MRT               | BEL1003285 | 3        |

**TO FIT HESSTON**

| BALER MODEL | MANUFACTURER'S PART NO. | DESCRIPTION   | SIZE        | FLAPS/BALER | 3 PLY BALER FLAPS |            | SHIP WT. |
|-------------|-------------------------|---------------|-------------|-------------|-------------------|------------|----------|
|             |                         |               |             |             | FINISH            | PART NO.   |          |
| 560 - 565   | 700711997               | Starter Flaps | 3.5 x 61.18 | 4           | MRT               | BEL1003285 | 3        |

**TO FIT NEW IDEA**

| BALER MODEL | MANUFACTURER'S PART NO. | DESCRIPTION   | SIZE        | FLAPS/BALER | 3 PLY BALER FLAPS |            | SHIP WT. |
|-------------|-------------------------|---------------|-------------|-------------|-------------------|------------|----------|
|             |                         |               |             |             | FINISH            | PART NO.   |          |
| 4665        | 700711997               | Starter Flaps | 3.5 x 61.18 |             | MRT               | BEL1003285 | 3        |



**BALE THROWER BELT**

| DIAMOND TOP - 2 PLY |     |                    |             |
|---------------------|-----|--------------------|-------------|
| WIDTH               | PLY | TEXTURE TOP/BOTTOM | PART NUMBER |
| 12"                 | 2   | DT                 | BEL1003198  |



DT - Diamond Top



## BEAN WINDROWER BELTS



WCCO Belting, Inc.

### RUB-R-CLEAT™

Vulcanized with Fiberglass rod and reinforced rubber cleats for extra strength and flexibility. The canvas is double reinforced in the center and along both edges. Designed to hold dimensional stability under heavy stress and above-normal loads.

### HEATH (HFE)

| MODEL NUMBER | MANUFACTURERS NUMBER | SIZE         | WESTWARD PART NUMBER | RUB-R-CLEAT PART NUMBER | WEIGHT (LBS) |
|--------------|----------------------|--------------|----------------------|-------------------------|--------------|
| 1050, 1082   | 080-025              | 31.31x140    | -                    | 1008963                 | 17           |
| 1060         | 080-019              | 31.31x235.75 | -                    | 1008967                 | 29           |
| 1062         | 080-032              | 31.31x77     | -                    | 1008966                 | 10           |
| 1080         | 080-033              | 31.31x325.75 | -                    | 1008969                 | 38           |
|              | 080-047              | 31.31x39.5   | -                    | 1008965                 | 5            |
|              | 080-064              | 31.31x84.5   | -                    | 1008968                 | 12           |
|              | 080-068              | 31.31x124    | -                    | 1008964                 | 14           |

Call for information if part numbers are not listed (-)

### LOCKWOOD-INNES/PICKETT

| MODEL NUMBER           | MANUFACTURER'S NUMBER | SIZE        | WESTWARD PART NUMBER | RUB-R-CLEAT PART NUMBER | WEIGHT (LBS) |
|------------------------|-----------------------|-------------|----------------------|-------------------------|--------------|
| 635                    | 22121-1               | 31.88x67.5  | -                    | 1008970                 | 9            |
| 700C-735               | 21826-1               | 31.88x92    | -                    | 1008971                 | 12           |
| 835-PP2H               | 22306-1               | 31.88x115.5 | BEL1008972           | 1008972                 | 13           |
| 200-400-500-500A3-PP86 | 21524-1               | 31.88x129   | -                    | 1008973                 | 14           |
|                        | 102125                | 31.88x246   | -                    | 1013973                 | 17           |
| 4P2-450-520            | 22493-1               | 31.88x140   | -                    | 1008974                 | 20           |
| 4P7-570                | 22433-1               | 31.88x172   | -                    | 1008975                 | 21           |
| 700R-PP163             | 22313-1               | 31.88x179   | -                    | 1008976                 | 26           |
| 4P9-835                | 22496-1               | 31.88x236   | BEL1008977           | 1008977                 | 28           |
| 925                    | 22943-1               | 31.88x381   | -                    | 1008978                 | 48           |
| A6036-2-A              | 102059                | 31.88x306   | -                    | 1014911                 | 40           |
| C8030                  | 102057                | 31.88x354   | -                    | 1014912                 | 47           |

Call for information if part numbers are not listed (-)

## RUB-R-CLEAT WINDROW INVERTER BELTS

| TO FIT NEW HOLLAND |               |                  |                |              |                        |     |
|--------------------|---------------|------------------|----------------|--------------|------------------------|-----|
| PART NO.           | MODEL         | MFG. NO.         | DESCRIPTION    | SIZE         | DESCRIPTION            | WT. |
| BEL1003330         | No. 144 & 166 | 850690, 86635705 | Center V-Guide | 35.2 x 176.5 | Draper/Laced           | 43  |
| BEL1005181         | No. 166 Only  | 86623246         | Side V-Guide   | 35.25 x 125  | Draper Extension Laced | 31  |



**CRESCENT TOP CONVEYOR BELTS**

WCCO's COBRA™ belt construction is a premium design for conveyor systems that require flexing and trough-ability.

It's made with a polyester-nylon filament fabric. Engineered with nylon in the weft direction, it promotes curving and flexibility during operation. Our COBRA™ conveyor belting is available in multiple texture, pattern, and cleat options.



| PART NUMBER | WIDTH (IN) | DESCRIPTION   | WCCO PART |
|-------------|------------|---|-----------|
| BEL1005575  | 12"        | 2 PLY "ULTIMATE" CRESCENT TOP X BAREBACK<br>(150 lb., Poly/Nylon, .319 OAG) | 1005575   |
| BEL1005577  | 16"        |   | 1005577   |
| BEL1005677  | 20"        |   | 1005677   |



Orders shipped in minimum quantity of 100 feet. Actual length of rolls may vary +/- 10% each.

• Moderately Oil Resistant

**CHEVRON TOP CONVEYOR BELT - COBRA™ ULTIMATE I**

| PART NUMBER | WIDTH (IN) | DESCRIPTION                                     | WCCO PART |
|-------------|------------|---|-----------|
| BEL1005052  | 15         | 2-PLY CTxSLB<br>150 lb/in POLY/NYLON 0.252" OAG | 1005052   |
| BEL1005053  | 20         |   | 1005053   |
| BEL1005047  | 24         |   | 1005047   |



Orders shipped in minimum quantity of 100 feet. Actual length of rolls may vary +/- 10% each.

**COBRA™ WEB-CLEAT CONVEYOR BELTING**

Testing proves the Web-Cleat can convey at a 40° ANGLE and over 25% FASTER than standard belt patterns such as crescent or chevron.

Standard belt patterns are used in multiple applications to improve the upward movement of materials. Yet the lack of pattern height loses the fight against the power of gravity and as a result these two patterns are restricted to a 20° to 30° incline conveying at sluggish speeds when compared to paddle belts.

| PART NUMBER | PLY | PIW WORKING TENSION | FABRIC     | BELT GAUGE | CLEAT  | BOTTOM | WIDTH | WCCO PART |
|-------------|-----|---------------------|------------|------------|--|--------|-------|-----------|
| BEL1012564  | 2   | 150 lb/in           | POLY/NYLON | 0.252"     | 2" WEB-CLEAT<br>CLEAT TO EDGE<br>7" CLEAT SPACING          | BARE   | 12    | 1012564   |
| BEL1011746  | 2   | 150 lb/in           | POLY/NYLON | 0.252"     | 2" WEB-CLEAT<br>1.5" RECESS BOTH SIDES<br>7" CLEAT SPACING | BARE   | 15    | 1011746   |
| BEL1012401  | 2   | 150 lb/in           | POLY/NYLON | 0.252"     | 2" WEB-CLEAT<br>2" RECESS BOTH SIDES<br>7" CLEAT SPACING   | BARE   | 16    | 1012401   |

The web area is molded with offset angles and a convex profile which promotes the directional flexing of the paddles and boosts their ability to carry material

The width of the inner paddles is reduced so the belt can seamlessly conform to the tube diameter without the risk of paddle interference to optimize a smooth transition

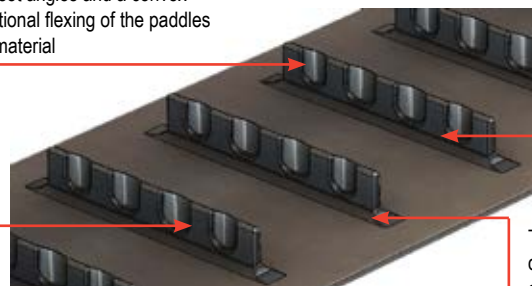

The inside radius between the paddles is curved to maximize belt support and increase belt durability

The base of the paddle has a fanned design to decrease the chance of wear on the back side of the belt

## COMBINE PICKUP BELTS

The teeth on WCCO'S pickup belts are made with a specially engineered plastic compound that was designed to withstand the roughest field conditions. The unique flex construction of the teeth alongside WCCO's belt construction help to maximize harvesting capacity.



### CASE IH

| PART NUMBER   | MODEL                           | MFR. NO.     | TYPE  | SIZE (IN)         | WCCO PART     | LB      |    |
|---------------|---------------------------------|--------------|---|-------------------|---------------|---------|----|
| BEL21-IH058   | 810, 820, 914<br>Pickup Header  | 185-528-C93  | Pickup Belt - No Teeth                        | 21.75 x 56.75     | 1000777       | 7       |    |
| BEL21-IH058WT |                                 |              | Pickup Belt - w/56 Teeth, Assembled           |                   | -             | -       |    |
| BEL21-IH060   | 1015, 403, 503<br>Pickup Header | 131-6715-C91 | Pickup Belt - No Teeth                        | 21.75 x 60.13     | 1000872       | 8       |    |
| BEL21-IH060WT |                                 |              | Pickup Belt - w/60 Teeth, Assembled           |                   | -             | -       |    |
| BEL21-RU059   | 2015<br>2016                    | -            | Front Belt, 1/4" Cleat, Bolt On, Holes        | 18.75 x 57.75     | 1002970       | 6       |    |
| BEL21-RU059WT |                                 | -            | Pickup Belt - w/42 Teeth, Assembled           |                   | -             | -       |    |
| BEL21-RU058   |                                 | -            | Rear Belt, 1/4" Cleat, Bolt On, Plain         |                   | 18.75 x 57.75 | 1002969 | 6  |
| BEL1012232    |                                 | -            | Front Belt, 1/4" Cleat, 42 Teeth, Unassembled |                   | 18.75 x 57.75 | 1012232 | 10 |
| BEL1012063    | 3016                            | -            | Rear Belt, 1/2" Cleat                         | 59.654" x 64.567" | 1012063       |         |    |
| BEL1012062    |                                 | -            | Front Belt - No Teeth                         | 59.654" x 64.567" | 1012062       |         |    |

### JOHN DEERE

| PART NUMBER   | MODEL  | MFR. NO.           | TYPE   | SIZE (IN)      | WCCO PART | LB |
|---------------|--|--------------------|--|----------------|-----------|----|
| BEL21-JD051   | 66-88<br>Two Roller                            | AH64826            | Pickup Belt - No Teeth   | 22 x 50.75     | 1000873   | 5  |
| BEL21-JD051WT |  |                    | Pickup Belt w/42 Teeth, Assembled  |                | -         | -  |
| BEL21-JD066   | 110, 132, 212<br>214, 912, 914<br>Three Roller | AH99200-<br>147908 | Pickup Belt - No Teeth   | 22 x 66.53     | 1000863   | 8  |
| BEL21-JD066WT |  |                    | Pickup Belt w/60 Teeth, Assembled  |                | -         | -  |
| BEL21-JD615   | 615P   | AH218051           | Front Belt, 0.375" Cleat<br>84 Holes - No Teeth<br>Bolt Together Splice  | 44.48 x 57.30  | 1010700   | 18 |
| BEL21-JD615WT |  |                    | Pickup Belt w/84 Teeth, Assembled  |                | -         | -  |
| BEL1010763    |  | AH217737           | Front Belt, 0.375" Cleat<br>84 Teeth (Assembled)<br>Bolt Together Splice | 44.48 x 57.30  | 1010763   | 25 |
| BEL1012624    |  | H218052            | Rear Belt, 0.25" Cleat<br>Bolt Together Splice                           | 44.48 x 67.717 | 1012624   | 21 |

### MASSEY FERGUSON

| PART NUMBER   | MODEL | MFR. NO.    | TYPE                              | SIZE (IN)  | WCCO PART | LB |
|---------------|-------|-------------|-----------------------------------|------------|-----------|----|
| BEL21-RN065   | MF67  | 1051-100-MI | Pickup Belt - No Teeth            | 22 x 65.75 | 100850    | 8  |
| BEL21-RN065WT |       |             | Pickup Belt w/70 Teeth, Assembled |            | -         | -  |

### MELROE

| PART NUMBER | MODEL                      | MFR. NO. | TYPE                   | SIZE (IN)        | WCCO PART | LB |
|-------------|----------------------------|----------|------------------------|------------------|-----------|----|
| BEL351378   | -                          | 351378   | Pickup Belt - No Teeth | 17-7/8"x45"      | 1002775   |    |
| BEL6528270  | 350, 351, 378,<br>388, 395 |          | Rear Conversion Belt   | 17-3/4" x 27.35" | 1002770   | 3  |

### NEW HOLLAND

| PART NUMBER | MODEL | MFR. NO.                       | TYPE        | SIZE (IN)         | WCCO PART | LB |
|-------------|-------|--------------------------------|-------------|-------------------|-----------|----|
| BEL1012066  |       | 84203799, AH93943,<br>AH147909 | Pickup Belt | 59.645" x 54.678" | 1012066   |    |



WCCO Belting, Inc.

## COMBINE PICKUP BELTS

### RAKE-UP/SWATHMASTER

| PART NUMBER   | MODEL       | MFR. NO.    | TYPE   | SIZE (IN)                                     | WCCO PART     | LB      |   |
|---------------|-------------|-------------|--|---|---------------|---------|---|
| BEL21-RU056   | Rake-Up     | 31-10100-01 | Rear Belt, 1/4" Cleat Lacing and Pin, Plain  | 18.75 x 56.25                                 | 1002509       | 7       |   |
| BEL21-RU058   |             | 31-10100-20 | Rear Belt, 1/4" Cleat Bolt On, Plain         | 18.75 x 57.75                                 | 1002969       | 6       |   |
| BEL21-RO057   | Swathmaster | 31-10100-05 | Front Belt, 1/4" Cleat Lacing and Pin, Holes | 18.75 x 56.25                                 | 1002507       | 7       |   |
| BEL21-RO057WT |             |             | Pickup Belt w/42 Teeth, Assembled            |   | -             | 10      |   |
| BEL21-RU059   |             | 31-10100-21 | Front Belt, 1/4" Cleat Bolt On, Holes        | 18.75 x 57.75                                 | 1002970       | 10      |   |
| BEL21-RU059WT |             |             | Pickup Belt w/42 Teeth, Assembled            |   | -             |         |   |
| BEL1012232    |             |             |  | Front Belt, 1/4" Cleat 42 Teeth - Unassembled | 18.75 x 57.75 | 1012232 | 7 |
| BEL21-RU056   |             |             | 31-10100-01                                  | Rear Belt, 1/4" Cleat Lacing and Pin, Plain   | 18.75 x 56.25 | 1002509 | 7 |
| BEL21-RU058   |             |             | 31-10100-20                                  | Rear Belt, 1/4" Cleat Bolt On, Plain          | 18.75 x 57.75 | 1002969 | 6 |

### RENN

| PART NUMBER   | MODEL    | MFR. NO. | TYPE                              | SIZE (IN)  | WCCO PART | LB |
|---------------|----------|----------|-----------------------------------|------------|-----------|----|
| BEL21-JD051   | 970      | 144-0905 | Pickup Belt - No Teeth            | 22 x 50.75 | 1000873   | 5  |
| BEL21-JD051WT |          |          | Pickup Belt w/42 Teeth, Assembled |            | -         |    |
| BEL21-RN065   | 990, 992 | 144-0913 | Pickup Belt - No Teeth            | 22 x 65.75 | 1000850   | 8  |
| BEL21-RN065WT |          |          | Pickup Belt w/70 Teeth, Assembled |            | -         |    |

### WHITE

| PART NUMBER   | MODEL | MFR. NO. | TYPE                              | SIZE (IN)    | WCCO PART | LB |
|---------------|-------|----------|-----------------------------------|--------------|-----------|----|
| BEL21-WH051   | -     | 2730570  | Pickup Belt - No Teeth            | 23.62 x 50.5 | 1000874   | 7  |
| BEL21-WH051WT |       |          | Pickup Belt w/70 Teeth, Assembled |              | -         |    |

### VICTORY

| PART NUMBER   | MODEL        | MFR. NO.     | TYPE  | SIZE (IN)                                      | WCCO PART    | LB      |
|---------------|--------------|--------------|---|--|--------------|---------|
| BEL21-VT042   | -            | 01290-110001 | Front Belt, Holes Elevator Bolts and Nuts     | 17.5 x 44.25                                   | 1002714      | 5       |
| BEL21-VT042WT |              |              | Pickup Belt w/60 Teeth, Assembled             |  | -            |         |
| BEL21-VT043   | -            | 01300-110002 | Rear Belt Elevator Bolts and Nuts             | 17.5 x 44.25                                   | 1002712      | 5       |
| BEL21-VT042   | Super Series | 01290-110001 | Front Belt, Holes Elevator Bolts and Nuts     | 17.5 x 44.25                                   | 1002714      | 5       |
| BEL21-VT042WT |              |              | Pickup Belt w/60 Teeth, Assembled             |  | -            |         |
| BEL21-VT044   |              |              | 013005-11003                                  | Rear Belt, 0.53" Cleat Elevator Bolts and Nuts | 17.5 x 53.56 | 1002713 |
| BEL21-VT045   | -            | 720010       | Front Belt, 0.53" Cleat, Holes Elevator Bolts | 17.5 x 53.5                                    | 1003114      | 6       |



**ON BELTS WITH TEETH - BELTS ONLY QUALIFY FOR OUR LIMITED WARRANTY**

## PLASTIC PICKUP TEETH & ELEVATOR BOLTS

### Plastic Pickup Teeth

| PART NO.   | DESCRIPTION                                      |
|------------|--|
| TIN491002  | 2¼" Plastic base flexi-tooth                     |
| TIN491004  | Left 2¼" Plastic base flexi-tooth                |
| TIN491005  | Right 2¼" Plastic base flexi-tooth               |
| TIN491006  | 2½" Plastic base flexi-tooth                     |
| TIN1470164 | Renn Pickup tooth                                |
| TIN1002936 | Single Prong Bolt-on Teeth for Victory (50/pkg.) |
| TIN491010  | WP drum Pick-up tooth                            |
| TIN491020  | Square Rubber block for drum pick-up             |



### Elevator Bolts

| ELEVATOR BOLTS |       |       |       |       |       |       |   |
|----------------|-------|-------|-------|-------|-------|-------|---|
| PART NO.       | A     | B     | C     | D     | E     | F     | DESCRIPTION                               |
| TIN491202-100  | 0.95" | 0.25" | 0.25" | 0.40" | 0.75" | 0.25" | ¼" x ¾" Elevator Bolt & Nut (100 per pkg) |
| TIN491203-100  | 0.95" | 0.25" | 0.25" | 0.60" | 1.00" | 0.25" | ¼" x 1" Elevator Bolt & Nut (100 per pkg) |
| TIN491204-50   |       |       |       |       |       |       | ¼" Serrated Flange Nut (50 per pkg)       |

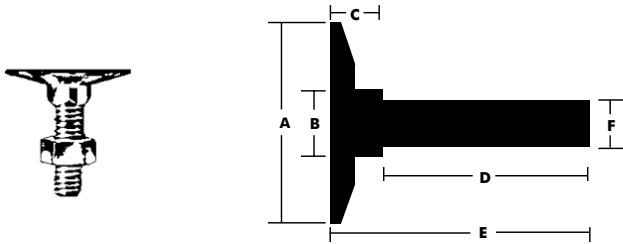

**PLASTIC REEL TINES**

**Hart Carter Replacement Reel Tines**

| PART NO.  | SIZE | DESCRIPTION  | APPLICATION   |
|-----------|------|--|---|
| TIN224016 | 4"   | 4" Double Wing Plastic Bat Finger for Hart Carter ML Series                      | John Deere, New Holland, Honeybee, Agco/Allis & Case-IH. Suits almost all Reels sold on these machines 1990-1998 with Pipe Bats (Hart Carter Reels) 4-1/2", 112 mm spacing  |
| TIN224047 | 6"   | 6" Double Wing Plastic Bat Finger for Hart Carter Level II Reels With 6" Spacing | Agco-Gleaner: 700, 800, 7000, 8000 and 8200 series. Replaces 71389106; Case-IH: 1020, 2010, 2020, 3020 series. Replaces 86608281, 86620758, 410856A1; Honey Bee: Replaces 26962; John Deere: 900D, 900F, 900R, 600F, 600R Series. Replaces AH166489; Massey Ferguson: 8000, 8200, 9250, 9800 and 9850 series. Replaces 71389106; Lexion: F20, F25, F30, F525, F530, F535, F540 series. Replaces 3526090; New Holland: 71C, 72C, 73C, 74C, 92C, 94C, 740CF Series, Replaces 86608281 |



**5 Finger Quick Tines**

Replacement Snap-On Tine For Agco, Case IH, Hart Carter, Honeybee, John Deere, Lexion, MacDon and New Holland Draper Headers. Designed to fit over existing finger.

| PART NO.  | DESCRIPTION   | MAKE/MODELS   | DESIGNED TO FIT OVER   |
|-----------|---|---|--|
| TINA11118 | 5 Finger Quick Tine for JD Headers                              | John Deere Header Models 630FD, 635FD, 640FD, 645FD, 730FD, 735FD, 740FD, 745FD, Serial # 785,000 and above.  | HXE96538, KXE10423<br>KXE10424   |
| TINA11125 | 5 Finger Quick Tine for Case IH, MacDon and New Holland Headers | Case IH 2142, 2152, 2162; MacDon D1, D50, D60, D65, FD1, FD70, FD75; New Holland 82C, 83C & 86C Series  | Case IH 84331097, 84331098<br>MacDon 137987, 174849, 174850<br>NH 87561020   |
| TINA11137 | 5 Finger Quick Tine for HCC Level II Headers                    | Agco 300, 400, 500, 700, 800, 7000, 8000, 8200 and 9250. Case IH 1010, 1020, 2010, 2020 and 3020; Honeybee; JD 900, 900D, 900F, 900R, 600F, 600R and 600FD before serial # 785,000; Lexion F20, F25, F30, F525, F530, F535 and F540; Massey Ferguson 8000, 8200, 9250, 9700, 9750, 9800 and 9850; New Holland 71C, 72C, 73C, 74C, 92C, 94C, 740C, 740CF, 971 and 973. | Agco 71389106<br>Case IH 86608281, 86620758, 410856A1<br>Honeybee 26962<br>John Deere AH166489<br>Massey Ferguson 71389106<br>Lexion 3526090<br>New Holland 86608281 |



**Universal Quick Finger**

| PART NO.   | DESCRIPTION               | SIZE               |
|------------|---------------------------|--------------------|
| TINQF1-10  | Quick Finger - Bag of 10  | Tine Length 7 1/4" |
| TINQF1-250 | Quick Finger - Bag of 250 |                    |

## HARVEST HEADER DRAPERS

**RAPTOR® is not only the most durable draper belt on the market, but its patented design REDUCES THE TOTAL COST OF OWNERSHIP OF EQUIPMENT, IMPROVES PRODUCTIVITY, and INCREASES THE BOTTOM LINE OF THE OPERATION for harvesters worldwide.**

Drapers must be able to withstand the impact force of common debris or an operator risks down-time and escalating replacement costs. If debris does cause damage to the draper belt, the subsequent concern of the operator is the likelihood of the puncture tearing and propagating. Puncture and tear properties also directly affect the hook retention of the belt's splice which is a high-stress area and most common belt failure mode.



WCCO Belting, Inc.



### HONEY BEE

| PART NUMBER | MODEL       | MFR. NO. | TYPE                                | CUT (FT) | SIZE (IN) | WCCO PART | LB |
|-------------|-------------|----------|-------------------------------------|----------|-----------|-----------|----|
| CAN1003122  | Feeder Deck | 73403    | Feeder, Connector Assembly          | -        | 68.75x65  | 1003122   | 27 |
| CAN1008206  | Feeder Deck | 76236    | Feeder, V-Guide, Connector Assembly | -        | 68.75x63  | 1008206   | 27 |

### JOHN DEERE

| PART NUMBER | MODEL                        | MFR. NO.             | TYPE                   | CUT (FT) | SIZE (IN)    | WCCO PART | LB |
|-------------|------------------------------|----------------------|------------------------|----------|--------------|-----------|----|
| CAN1009245  | 925D                         | AXE39582, AH159533   | Draper                 | 25       | 36x244       | 1009245   | 38 |
| CAN1009244  | 930D                         | AXE39583, AH159534   | Draper                 | 30       | 36x304       | 1009244   | 47 |
| CAN1009243  | 936D                         | AXE39584, AH159535   | Left Draper            | 36       | 36x332       | 1009243   | 52 |
| CAN1009242  | 936D                         | AXE39585, AH159536   | Right Draper           | 36       | 36x420       | 1009242   | 65 |
| CAN1009246  | 930D<br>Windrow Option       | AXE39586, AH159557   | Fixed Side Draper      | 30       | 36x86.44     | 1009246   | 13 |
| CAN1009247  | 930D, 936D<br>Windrow Option | AXE39587<br>AH159558 | Movable<br>Side Draper | 30<br>36 | 36x218.44    | 1009247   | 33 |
| BEL1003426  | 925D, 930D, 936D             | AH203047, AH173119   | Feeder Belt            |          | 60x63.56     | 1003426   | 25 |
| CAN1009381  | 630D                         | AXE15008             | Draper                 | 30       | 39.54x297.13 | 1009381   | 49 |
| CAN1009382  | 635D                         | AXE14603, AXE12532   | Draper                 | 35       | 39.54x357.13 | 1009382   | 59 |
| CAN1009383  | 640D                         | AXE15009, AXE16051   | Draper                 | 40       | 39.54x417.13 | 1009383   | 69 |
| CAN1008293  | 625D, 630D, 635D,<br>640D    | AXE12117, AXE12533   | Feeder Belt            | -        | 55.3x58.01   | 1008293   | 24 |

### JOHN DEERE - ENDLESS RAPTOR DRAPERS

| PART NUMBER | MODEL  | MFR. NO. | TYPE                           | CUT (FT)             | SIZE (IN)    | WCCO PART | LB |
|-------------|--|----------|--------------------------------|----------------------|--------------|-----------|----|
| CAN1011081  | 635FD<br>Serial 784999 & Earlier<br>4 Belts per Model  | AXE35348 | Endless Draper<br>Side V-Guide | 35                   | 39.93x185.4  | 1011081   | 34 |
| CAN1011081  | 640FD<br>Serial 784999 & Earlier<br>4 Belts per Model  | AXE35348 | Endless Draper<br>Side V-Guide | 40                   | 39.93x185.4  | 1011081   | 35 |
| CAN1011083  |  | AXE35349 | Endless Draper<br>Side V-Guide | 40                   | 39.93x245.4  | 1011083   | 45 |
| BEL1011087  | 630FD, 635FD, 640FD<br>Serial Number 740635-784999<br>1 Belt per Model   | AXE17364 | Feeder Belt<br>Double V-Guide  | 30<br>35<br>40       | 58.10x51.85  | 1011087   | 24 |
| CAN1013441  | 630FD<br>Serial 785000 & Later, 2 Belts per Model  | AXE31445 | Endless Draper<br>Side V-Guide | 30                   | 39.93x295    | 1013441   | 54 |
| CAN1013435  | 635FD<br>Serial 785000 & Later, 4 Belts per Model  | AXE36550 | Endless Draper<br>Side V-Guide | 35                   | 39.93x180    | 1013435   | 33 |
| CAN1013435  | 640FD<br>Serial 785000 & Later<br>4 Belts per Model  | AXE36550 | Endless Draper<br>Side V-Guide | 35                   | 39.93x180    | 1013435   | 33 |
| CAN1013438  |  | AXE36551 | Endless Draper<br>Side V-Guide | 40                   | 39.93x239.75 | 1013438   | 44 |
| CAN1013438  | 645FD<br>Serial 785000 & Later, 4 Belts per Model  | AXE36551 | Endless Draper<br>Side V-Guide | 45                   | 39.93x239.75 | 1013438   | 44 |
| CAN1013563  | 630FD Serial 785000 & Later<br>635FD Serial 785000 & Later<br>640FD Serial 785000 & Later<br>645FD Serial 785000 & Later<br>730FD, 735FD, 740FD, 745FD<br>1 Belt per Model | HXE49231 | Feeder Belt<br>Double V-Guide  | 30<br>35<br>40<br>45 | 69.80x51.85  | 1013563   | 29 |



WCCO Belting, Inc.

## HARVEST HEADER DRAPERS

### JOHN DEERE FEEDER BELT OPTION

This feeder belt uses WCCO's crescent pattern. It's designed to promote a continual and even feed from the belt into the feeder auger.

| PART NUMBER | MODEL  | MFR. NO.                        | TYPE   | CUT (FT)             | SIZE (IN)   | LB |
|-------------|--|---------------------------------|--|----------------------|-------------|----|
| CAN1013749  | 630FD Serial 785000 & Later<br>635FD Serial 785000 & Later<br>640FD Serial 785000 & Later<br>645FD Serial 785000 & Later<br>730FD, 735FD, 740FD, 745FD<br>1 Belt per Model | HXE124019<br>AXE71261<br>OPTION | Feeder Belt<br>1-Ply CRTxTB<br>Double V-Guide<br>with Steel Tube<br>Connector Assembly | 30<br>35<br>40<br>45 | 69.80x51.85 | 30 |



### MACDON

| PART NUMBER | MODEL   | STYLE                             | MFR. NO. | TYPE   | CUT (FT)                 | SIZE (IN)  | WCCO PART | LB |
|-------------|---|-----------------------------------|----------|--|--------------------------|------------|-----------|----|
| CAN1009277  | 960 Harvest Header<br>1995-2000 Production        | Double Delivery                   | 49518    | Draper, Side V-Guide                               | 30 LH, 30 RH             | 41.6x297.8 | 1009277   | 45 |
| CAN1009278  |   | Double Delivery                   | 49519    | Draper, Side V-Guide                               | 30 RH                    | 41.6x345   | 1009278   | 52 |
| CAN1009277  |   | Triple Delivery                   | 49518    | Draper, Side V-Guide                               | 30 LH, 30 RH             | 41.6x297.8 | 1009277   | 45 |
| CAN1003452  | Models Before 1992                                | -                                 | 37105    | Feeder Belt<br>Side V-Guide<br>Recessed 3/4" Cleat | -                        | 41.5x85.75 | 1003452   | 28 |
| CAN1003451  |   | -                                 | 40698    | Feeder Belt<br>Side V-Guide<br>Recessed 3/4" Cleat | -                        | 59.5x85.75 | 1003451   | 35 |
| CAN1003452  | Models After 1992                                 | -                                 | 40697    | Feeder Belt<br>Side V-Guide<br>Recessed 3/4" Cleat | -                        | 41.5x85.75 | 1003452   | 28 |
| CAN1003451  |   | -                                 | 40698    | Feeder Belt<br>Side V-Guide<br>Recessed 3/4" Cleat | -                        | 59.5x85.75 | 1003451   | 35 |
| BEL1003455  | 871, 872, 873<br>Adapter                          | Case IH<br>Gleaner<br>New Holland | 101671   | Feeder Belt  | -                        | 38.4x97    | 1003455   | 28 |
| CAN1009277  | 962, 963,<br>Harvest Header<br>Case-IH 1042, 2042 | Double Delivery                   | 100265   | Draper<br>Side V-Guide                             | 30 LH                    | 41.6x297.8 | 1009277   | 45 |
| CAN1009278  |   | Double Delivery                   | 100266   | Draper<br>Side V-Guide                             | 30 RH                    | 41.6x345   | 1009278   | 52 |
| CAN1009287  | 972 Harvest Header<br>Case-IH 1052, 2052,<br>2062 | Double Delivery                   | 100275   | Draper, Side V-Guide                               | 21                       | 41.6x201   | 1009287*  | 30 |
| CAN1009288  |   | Double Delivery                   | 100438   | Draper, Side V-Guide                               | 25                       | 41.6x249   | 1009288*  | 37 |
| CAN1009289  |   | Double Delivery                   | 101912   | Draper, Side V-Guide                               | 30 RH                    | 41.6x309   | 1009289*  | 46 |
| CAN1003467  |   | -                                 | 114267   | Feeder Belt  | -                        | 45.4x97    | 1003467   | 27 |
| CAN1009291  |   | Double Delivery                   | 101913   | Draper, Side V-Guide                               | 36 LH                    | 41.6x357   | 1009291   | 54 |
| CAN1009292  |   | Double Delivery                   | 101914   | Draper, Side V-Guide                               | 36 RH                    | 41.6x405   | 1009292   | 61 |
| CAN1009287  | 973, 974<br>Harvest Header                        | Center Delivery                   | 100275   | Draper, Side V-Guide                               | 21                       | 41.6x201   | 1009287   | 30 |
| CAN1009288  |   | Center Delivery                   | 100438   | Draper, Side V-Guide                               | 25                       | 41.6x249   | 1009288   | 37 |
| CAN1009289  |   | Center Delivery                   | 101912   | Draper, Side V-Guide                               | 30                       | 41.6x309   | 1009289   | 46 |
| CAN1009291  |   | Center Delivery                   | 101913   | Draper, Side V-Guide                               | 36 LH                    | 41.6x357   | 1009291   | 54 |
| CAN1009292  |   | Center Delivery                   | 101914   | Draper, Side V-Guide                               | 36 RH                    | 41.6x405   | 1009292   | 61 |
| CAN1009288  |   | End Delivery                      | 100438   | Draper, Side V-Guide                               | 36 Right<br>Inboard Deck | 41.6x249   | 1009288   | 37 |
| CAN1009288  |   | End Delivery                      | 100438   | Draper, Side V-Guide                               | 39 Right<br>Inboard Deck | 41.6x249   | 1009288   | 37 |

### MASSEY FERGUSON, GLEANER, CHALLENGER DH

| PART NUMBER | MODEL   | MFR. NO.  | TYPE   | CUT (FT) | SIZE (IN) | WCCO PART | LB |
|-------------|---|-----------|--------|----------|-----------|-----------|----|
| CAN1009302  | Massey 5000-5200, Gleaner<br>600, Challenger DH | 700726014 | Draper | 25       | 41x229.25 | 1009302   | 36 |

## PRECUT DRAPERS

WCCO's patented RAPTOR™ Belting uses 100% polyester filament fabric with a friction coating capability. Filament will always outperform a similar spun fabric with higher tensile, tear and puncture resistance; the fabric is also less volatile in pricing and is more readily in supply. Until RAPTOR™ technology, it was nearly impossible to friction coat filament fabric because the surface was too smooth for the rubber to form a strong bond. WCCO's draper features a friction coat on the underside of the belt which reduces weight and drag, and it uses a skim coat on the topside of the belt for optimal protection. RAPTOR™ draper belting has higher strength properties, superior durability, and has more stable market pricing compared to other conventional draper options.



| PART NUMBER | MODEL  | REPLACES  | TYPE                         | CUT (FT) | SIZE (IN)                            |
|-------------|--|---|------------------------------|----------|--------------------------------------|
| CAN1009271  | MacDon D60, D65, FD70, FD75 Case/IH - 2142 Rigid, 2152 Rigid, 2162 Flex, 2163 Flex | 145960, 172195, 220637  | V-Guide                      | 30       | 41.6" x 277.24"                      |
| CAN1009273  |  | 145962, 172197, 220639, 87560980, 47679353  | V-Guide                      | 40       | 41.6" x 397.24"                      |
| CAN1009984  |  | 84122227, 47767476  | V-Guide                      | 45       | 41.6" x 457.24"                      |
| CAN1010877  | MacDon D50, D60, D65, FD70, FD75 Case IH 2142, 2152, 2162 Flex                     | 133131, 304454, 87560973  | V-Guide                      |          | 78.5 x 63.75" (center feeder draper) |
| CAN1011332  | Massey Ferguson 9250 DynaFlex  | 71483142  | V-Guide                      | 35       | 41" x 363.70"                        |
| CAN1011333  |  | 7143811, 71483140   | V-Guide                      | 40       | 41" X 423.70"                        |
| CAN1012071  | CNH Terra Flex 3162 & 3152 Rigid NH 880 CF Super Flex & 840C Rigid                 | 165337, 172198, 220640, 84122227, 47767476, 47602166, 84399888                                  | Single V-Guide, no side seal | 45       | 41.6" X 447.40"                      |
| CAN1012070  |  | 145962, 172197, 220639, 87560980, 47679353  |                              | 40       | 41.6" X 387.40"                      |
| CAN1012069  |  | 1-899856L, AW20636, AW21039, AW21039, 825-801-C91, 825-802-C92, 1041-508-M92, 885230L, K-22924, |                              | 35       | 41.6" X 327.40"                      |
| CAN1012068  |  | 47371565 (LH), 47371566 (RH)  |                              | 30       | 41.6" X 267.40"                      |
| CAN1009630  | Honey Bee  | 83718   | V-Guide                      | 30       | 41.75" x 300"                        |
| CAN1009689  | Honey Bee  | 83717   | V-Guide                      | 30       | 41.75" x 272"                        |
| CAN1009691  | Honey Bee  | 83720   | V-Guide                      | 36       | 41.75" x 350"                        |
| CAN1009692  | Honey Bee  | 83721   | V-Guide                      | 36       | 41.75" x 374"                        |
| CAN1009694  | Honey Bee  | 83724   | V-Guide                      | 40       | 41.75" x 423"                        |



**TENSION – HOW THE BELT FITS**  
 RAPTOR® eliminates downtime caused by having to continuously re-tension using a high strength fabric with a self-adjusting patented weave.

**DRAG – HOW THE BELT RUNS**  
 RAPTOR's patented fabric technology reduces belt weight and the risk of slippage, stalling (yield-loss), and mistracking.

**DURABILITY – WHY THE BELT LASTS**  
 RAPTOR® redefines performance in puncture, tear, and tensile strength and has a rip-stop feature.





WCCO Belting, Inc.

**DRAPER BELTING BULK ROLLS**  
SEE ROLL LENGTH AVAILABILITIES BELOW

| PART NUMBER    | WCCO #  | WIDTH | EQUIPMENT             | DESCRIPTION  | ROLL SIZE | LB/FT |
|----------------|---------|-------|-----------------------|--|-----------|-------|
| CAN1009218     | 1009218 | 36    | John Deere            | Draper, Side V-Guide   | 150'      | 1.84  |
| CAN1010964     | 1010964 | 39.5  | Claas/Lexion          | Draper, Side V-Guide   | 150'      | 1.96  |
| CAN1008822     | 1008822 | 39.54 | John Deere            | Draper, Side V-Guide   | 150'      | 1.96  |
| CAN1008804     | 1008804 | 41    | Massey Ferguson, AGCO | Draper, Rubber Cleat   | 150'      | 1.96  |
| CAN1008804-300 | 1008804 | 41    | Massey Ferguson, AGCO | Draper, Rubber Cleat   | 300'      | 1.96  |
| CAN1009826     | 1009826 | 41    | Massey Ferguson       | Draper, Side V-Guide 0.79" Center to Edge                    | 150'      | 1.99  |
| CAN1011097     | 1011097 | 41    | Massey Ferguson       | Draper, Side V-Guide 2.6" Center to Edge                     | 150'      | 1.99  |
| CAN1008948     | 1008948 | 41.6  | MacDon                | Draper, Side V-Guide   | 150'      | 1.99  |
| CAN1011274     | 1011274 | 41.6  | Case IH, NH           | Draper, Side V-Guide, 0.63" Center to Edge                   | 150'      | 1.99  |
| CAN1008803     | 1008803 | 41.75 | Honey Bee             | Draper, Side V-Guide Recessed 3/8" Cleat                     | 150'      | 2.10  |
| CAN1013722     | 1013722 | 41.75 | Honey Bee             | Draper, Side V-Guide Recessed 1.5" Cleat on Non-V-Guide Side | 150'      | 2.10  |
| CAN1008787     | 1008787 | 42    | Honey Bee             | Draper, Rubber Cleat   | 150'      | 2.02  |

Rolls with side v-guides are only available in a 150 FT roll size with +/-10% potential roll length variance.  
Rolls without v-guides are available in 150 FT and 300 FT roll size with +/-10% potential roll length variance.



**CANVAS REPAIR PARTS**

| PART NUMBER | DESCRIPTION                  |
|-------------|------------------------------|
| CAN10       | Pkg. of Slat Bolts           |
| CANCR-1     | 1/2 lb. Pkg. of Rivets       |
| CANCS-1     | 1 Pint Tin of Solvent        |
| CANCG-1     | 1/2 Pint Tin of Glue         |
| CANSCM-1    | 4" Vinyl Material (per foot) |
| CANSCM-16   | 6" Vinyl Material (per foot) |



**STEEL TUBE CONNECTOR ASSEMBLIES**

| PART NUMBER | WCCO #  | SIZE (IN) | HOLES | EQUIPMENT       | DESCRIPTION   |
|-------------|---------|-----------|-------|-----------------|---|
| CAN1003863  | 1003863 | 35        | 7     | John Deere      | Steel Tube Connector  |
| CAN1008022  | 1008022 | 37.32     | 9     | Claas/Lexion    | Steel Tube Connector  |
| CAN1008230  | 1008230 | 38.78     | 7     | John Deere      | Steel Tube Connector  |
| CAN1003748  | 1003748 | 33.25     |       | Honey Bee       | 2 Sets, Steel Tube Connector Feeder Belts   |
| CAN1002752  | 1002752 | 40.5      | 8     | Massey Ferguson | Steel Tube Connector  |
| CAN1009832  | 1009832 | 39.88     | 11    | AGCO            | Steel Tube Connector  |
| CAN1003556  | 1003556 | 40        | 11    | Massey Ferguson | Metal Connector Cardboard Filled  |
| CAN1002377  | 1002377 | 39.8      | 11    | MacDon          | Steel Tube Connector  |
| CAN1005840  | 1005840 | 38.78     | 10    | MacDon          | Steel Tube Connector  |
| CAN1003729  | 1003729 | 41.375    | 11    | Honey Bee       | Steel Tube Connector  |
| CAN1013622  | 1013622 |           |       | John Deere      | 6.88"4H and 54.25"10H Steel Tube Connector Includes 2 Sets 6.88" and 1 Set 54.25" Serial No. 740635 & Later |



| PART NUMBER | DESCRIPTION                           | SIZE (IN) | EQUIPMENT |
|-------------|---------------------------------------|-----------|-----------|
| CAN1006722  | Galvanized Connector Cardboard Filled | 85        | Universal |
| CAN1007088  | Bolt Kit For Metal Connector          |           |           |

## CUTTING & INSTALLATION INSTRUCTIONS - Bulk Rolls

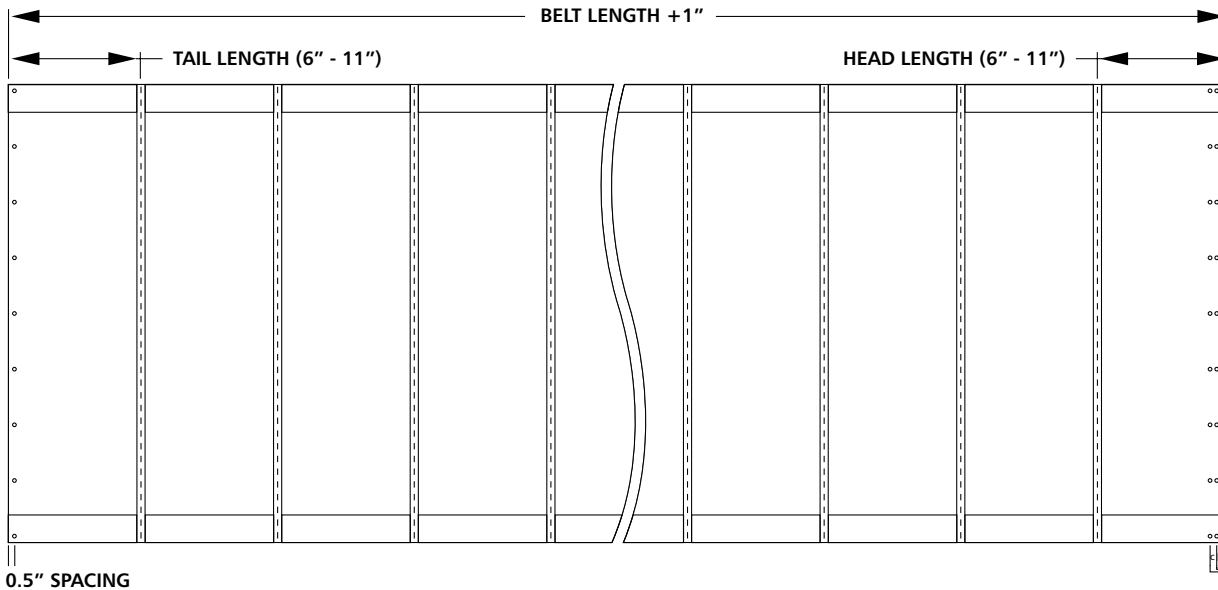

### CUTTING INSTRUCTIONS

1. Pull a length of bulk roll canvas out on a flat surface with the slats facing up.
2. When measuring the cutting length of the belt, add 1" to the length listed in the catalog.
3. When cutting the length of the belt, center the correct amount of slats over the belt length.
4. The dimensions of the head and tail (see diagram) should be as equal as possible. Try to keep the dimensions between 6.00 inches to 11.00 inches.
5. When you have finished cutting the length there are two options regarding the connector set:
  - A. Package connector set with the belt and have the customer punch the holes in the belt.
  - B. Use the connector as a template to mark / punch the holes as shown in the diagram.

- a 0.5" SPACING
- b 1.5" SPACING
- c 2.5" SPACING

### INSTALLATION INSTRUCTIONS

#### PREPARATION

1. Check all bearings for movement without drag or noise. Lubricate or replace as required.
2. Check for bent or broken rollers and replace as required. Free all rollers of rust and build up.
3. Eliminate catch points, weld splatters and sharp metal edges.

#### INSTALLATION

1. You can operate your WCCO Swather Belt in either direction. However, install the HEADS of the connector bolts so they are facing the direction most frequently operated to reduce catching of the crop.
2. Remove excess material on the flap. To prevent noisy slapping effect during operation, trim tail end flaps to 1/4" (inch) after the fastener bar has been tightened.
3. Belts will tend to edge toward the slack side of the roller. If distance "A" is less than distance "B", then the belt will tend to run toward the high side of the roller carriage. If distance "A" is greater than distance "B", then the belt will tend to run toward the low side of the roller carriage.
4. When adjusting the roller carriage, always keep the rollers parallel with each other. For the best results, measure roller ends diagonally across roller carriage making sure the distance from points "C" to "D" is EQUAL with the distance from point "E" to "F".

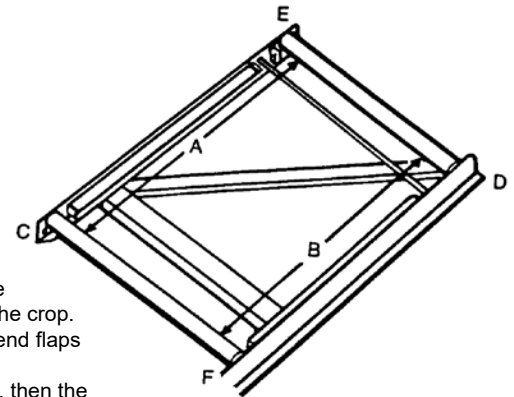

#### MAINTENANCE

1. Drapers should be removed when the machine is not to be used, or if it is exposed to weather for an extended period of time. Roller rust and deterioration caused by decaying materials, accelerated by wet conditions, can result in premature belt failure.
2. Store drapers in a protected, dry place.
3. On swathers using two belts of equal size, alternate belts periodically to even wear and extend belt life.
4. Before re-installing the belt for the next season, examine fastener bar connectors closely. Replace bent or broken connectors immediately to prevent belt damage.

## TUB GRINDER BELTS



WCCO offers standard cleat sizes that can help your customers effectively convey product for various operations including tub grinding. Made with our exclusive one-step process, you receive durable products that hold the same properties throughout.

Belt fabricators rely on processes such as using a skive and gluing surface features, such as cleats, to their products. Don't rely on glue, trust rubber science.

### TO FIT FARMHAND

| TUB GRINDER MODEL          | MFR. NO. | APPLICATION  | SIZE (IN) | DESCRIPTION                     | PART NO.   | LB |
|----------------------------|----------|--------------|-----------|---------------------------------|------------|----|
| F880A, F880B, F890B, XG-30 | 1A88611  | Top Conveyor | 18x399    | 2-Ply, 0.187" OAG<br>1.5" Cleat | BEL1003361 | 57 |

### TO FIT HAYBUSTER

| TUB GRINDER MODEL   | MFG. NO.   | APPLICATION  | SIZE     | DESCRIPTION                            | PART NO.   | SHIP WT. |
|---|------------|--------------|----------|--|------------|----------|
| H-900, H-1000, C-9 & C-10   | 1700001    | Top Conveyor | 16 x 472 | 2 Ply, 0.166" thick with 1 1/2" cleats | BEL1003374 | 60       |
| H-1000 (Late Models),<br>H-1000 Series II                               | 1700017    | Top Conveyor | 18 x 477 | 2 Ply, 0.166" thick with 1 1/2" cleats | BEL1003376 | 69       |
| C-11-C, H-1100 (Late Models),<br>H1100E Series II H1100 Tilt Series II  | 1700006    | Top Conveyor | 18 x 528 | 2 Ply, 0.166" thick with 1 1/2" cleats | BEL1003379 | 75       |
| C-11-C, H-1100 (Late Models),<br>H1100E Series II, H1100 Tilt Series II | 1700031    | Belly Apron  | 30 x 216 | 2 Ply, 0.237" thick with 3/4" cleats   | BEL1003381 | 49       |
| H-1150, H-1155  | BEL1700173 | Top Conveyor |          | 2-Ply, 0.187" OAG, 1.5" Cleat          | BEL1006665 | 195      |
| 1150 & 1155 Commercial, 1150<br>Grapple Loader                          | 1700178    | Top Conveyor | 24 x 645 | 2 Ply, 0.166" thick with 1 1/2" cleats | BEL1005827 | 125      |

### TO FIT INTERNATIONAL HARVESTER

| TUB GRINDER MODEL | MFG. NO.     | APPLICATION  | SIZE     | DESCRIPTION                            | PART NO.   | SHIP WT. |
|-------------------|--------------|--------------|----------|--|------------|----------|
|                   | 725-72758-C1 | Top Conveyor | 18 x 399 | 2 Ply, 0.166" thick with 1 1/2" cleats | BEL1003361 | 57       |

### TO FIT NEW HOLLAND

| TUB GRINDER MODEL | MFG. NO. | APPLICATION  | SIZE     | DESCRIPTION                            | PART NO.   | SHIP WT. |
|-------------------|----------|--------------|----------|--|------------|----------|
| 390, 391 & 393    |          | Top Conveyor | 18 x 399 | 2 Ply, 0.166" thick with 1 1/2" cleats | BEL1003361 | 57       |



## FASTENER SIZE SELECTION CHART

|                  |               | BELT THICKNESS |            |       |           |       |         |       |       |       |       |        |        |
|------------------|---------------|----------------|------------|-------|-----------|-------|---------|-------|-------|-------|-------|--------|--------|
| MIN PULLEY       | WIRE DIAMETER | UP TO 3/64     | 1/16"      | 3/32" | 1/8"      | 5/32" | 3/16"   | 7/32" | 1/4"  | 9/32" | 5/16" | 11/32" | 25/64" |
|                  |               | 1.2mm          | 1.6mm      | 2.4mm | 3.2mm     | 4.0mm | 4.8mm   | 5.6mm | 6.4mm | 7.1mm | 7.9mm | 9.0mm  | 10.0mm |
| 1 5/16"<br>24 mm | .025"         | 25SP*          |            |       |           |       |         |       |       |       |       |        |        |
|                  | .025"         | 25*            |            |       |           |       |         |       |       |       |       |        |        |
|                  | .036" x .027" | UCM36 XSP      |            |       |           |       |         |       |       |       |       |        |        |
|                  | .036" x .027" |                | UCM36SL SP |       |           |       |         |       |       |       |       |        |        |
|                  | .025"         |                | 25LP*      |       |           |       |         |       |       |       |       |        |        |
| 2"<br>51 mm      | .036" x .027" | UCM36 XSP      |            |       |           |       |         |       |       |       |       |        |        |
|                  | .030"         | 30°            |            |       |           |       |         |       |       |       |       |        |        |
|                  | .036" x .027" |                | UCM36 SP8  |       |           |       |         |       |       |       |       |        |        |
|                  | .036" x .027" |                | 36 SP*     |       |           |       |         |       |       |       |       |        |        |
|                  | .040"         |                | 1 XSP*     |       |           |       |         |       |       |       |       |        |        |
|                  | .030"         |                | 30P*       |       |           |       |         |       |       |       |       |        |        |
|                  | .040"         |                | UX 1 SP*   |       |           |       |         |       |       |       |       |        |        |
|                  | .036" x .027" |                | UCM36*     |       |           |       |         |       |       |       |       |        |        |
|                  | .036" x .027" |                | 36"        |       |           |       |         |       |       |       |       |        |        |
|                  | .040"         |                | 1 SP*      |       |           |       |         |       |       |       |       |        |        |
|                  | .036" x .027" |                |            |       | UCM36 LP* |       |         |       |       |       |       |        |        |
|                  | .040"         |                |            |       | 1"        |       |         |       |       |       |       |        |        |
|                  | .040"         |                |            |       | UX 1"     |       |         |       |       |       |       |        |        |
|                  | .047"         |                |            |       | UA2       |       |         |       |       |       |       |        |        |
|                  | .054"         |                |            |       | U2 SP     |       |         |       |       |       |       |        |        |
| .054"            |               |                |            | U2    |           |       |         |       |       |       |       |        |        |
| .047"            |               |                |            | UA3   |           |       |         |       |       |       |       |        |        |
| 3"<br>76 mm      | .054"         |                |            |       | 2 SP      |       |         |       |       |       |       |        |        |
|                  | .054"         |                |            |       |           | 2     |         |       |       |       |       |        |        |
| 3 1/2"<br>89 mm  | .054"         |                |            |       | U3-1      |       |         |       |       |       |       |        |        |
|                  | .054"         |                |            |       | 3-1       |       |         |       |       |       |       |        |        |
|                  | .054"         |                |            |       | U3-2      |       |         |       |       |       |       |        |        |
|                  | .054"         |                |            |       |           | 3     |         |       |       |       |       |        |        |
|                  | .054"         |                |            |       |           | U3    |         |       |       |       |       |        |        |
|                  | .054"         |                |            |       |           |       | 3-4-1/2 |       |       |       |       |        |        |
| 4"<br>102 mm     | .054"         |                |            |       |           | 4-2   |         |       |       |       |       |        |        |
|                  | .054"         |                |            |       |           |       | 4-1/2-3 |       |       |       |       |        |        |
|                  | .054"         |                |            |       |           |       | 4       |       |       |       |       |        |        |
|                  | .054"         |                |            |       |           |       |         | 4-1/2 |       |       |       |        |        |
| 5"<br>127 mm     | .054"         |                |            |       |           |       |         | U4    |       |       |       |        |        |
|                  | .054"         |                |            |       |           |       |         |       | 5     |       |       |        |        |
|                  | .054"         |                |            |       |           |       |         |       | U5    |       |       |        |        |
| 6"<br>152 mm     | .054"         |                |            |       |           |       |         |       |       | 4-1/2 |       |        |        |
|                  | .054"         |                |            |       |           |       |         |       |       | U6    |       |        |        |
| 7"<br>175 mm     | .054"         |                |            |       |           |       |         |       |       |       | 4-1/2 |        |        |
|                  | .054"         |                |            |       |           |       |         |       |       |       | U7    |        |        |

|  |         |
|--|---------|
|  | Unibar® |
|  | Carded  |

\*Long leg configuration is available; allow for 1 larger minimum pulley diameter.

**CLIPPER REGULAR (54) SERIES CARDED HOOKS**

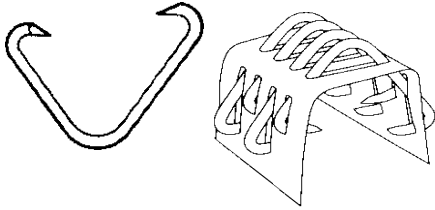

Carded hooks are individual hooks secured on carding paper for easier handling.

- Works with any application including bias splices and troughed belt applications.
- Available in a wide variety of metals.



| GALVANIZED - WITHOUT PINS - 12" LENGTHS |               |                 |                    |                |               |                       |
|---|---------------|-----------------|--------------------|----------------|---------------|-----------------------|
| HOOK SIZE                               | FLEXCO NUMBER | WESTWARD NUMBER | WT. PER BOX (LBS.) | HOOKS PER CARD | CARDS PER BOX | LACING INCHES PER BOX |
| 2SP                                     | 2SPG          | LACBUL2SP       | 1.2                | 84             | 12            | 144                   |
| 2                                       | 2G            | LACBUL2SP       | 1.2                | 84             | 12            | 144                   |
| 3                                       | 3G            | LACBUL3         | 1.3                | 84             | 12            | 144                   |
| 4                                       | 4G            | LACBUL4         | 1.4                | 84             | 12            | 144                   |
| 4 1/2                                   | 4 1/2G        | LACBUL4.5       | 1.5                | 84             | 12            | 144                   |

| HIGH TENSILE - WITHOUT PINS - 12" LENGTH |               |                 |                    |                |               |                       |
|--|---------------|-----------------|--------------------|----------------|---------------|-----------------------|
| HOOK SIZE                                | FLEXCO NUMBER | WESTWARD NUMBER | WT. PER BOX (LBS.) | HOOKS PER CARD | CARDS PER BOX | LACING INCHES PER BOX |
| 4  | 4HT           | LAC02223        | 1.4                | 84             | 12            | 144                   |

| RECTANGULAR HIGH TENSILE - WITHOUT PINS - 12" LENGTHS |               |                 |                    |                |               |                       |
|---|---------------|-----------------|--------------------|----------------|---------------|-----------------------|
| HOOK SIZE   | FLEXCO NUMBER | WESTWARD NUMBER | WT. PER BOX (LBS.) | HOOKS PER CARD | CARDS PER BOX | LACING INCHES PER BOX |
| 4-1/2-3   | 4-1/2-3RHTX   | LAC02432        | 2.3                | 84             | 12            | 144                   |
| 4-1/2   | 4-1/2RHTX     | LAC02429        | 2.3                | 84             | 12            | 144                   |

**CLIPPER 1 (40) SERIES CARDED HOOKS FASTENERS**

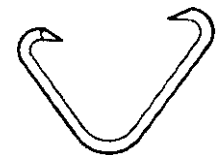

| GALVANIZED - WITHOUT PINS - 12" LENGTHS |               |                 |                    |                |               |                       |
|---|---------------|-----------------|--------------------|----------------|---------------|-----------------------|
| HOOK SIZE                               | Flexco Number | Westward Number | Wt. per Box (Lbs.) | Hooks per Card | Cards per Box | Lacing Inches Per Box |
| 1                                       | 1G12          | LACBUL1         | 0.6                | 96             | 12            | 144                   |

| COATED STEEL™ - WITHOUT PINS - 12" STRIPS - 10 STRIPS PER BOX |                          |                 |             |                |               |                |
|---|--------------------------|-----------------|-------------|----------------|---------------|----------------|
| HOOK SIZE   | Flexco Number            | Westward Number | Wt. per Box | Hooks per Card | Cards per Box | Lacing Per Box |
| 6 1/2"  | 4-1/2-4RHTX(42)-10POPHKS | LAC02435        | 1.1 LBS.    | 42             | 10            | 65"            |

## CLIPPER UNIBAR® SERIES HOOKS

Unibar® fasteners are formed by welding each Clipper® hook to a common bar.

- The patented safety strip covers the hook points to protect the user's fingers.
- Eliminates tangling in the box.
- Hook legs are held parallel, which eases the "meshing" of belt ends and the insertion of connecting pins.
- The risk of a single hook dislodging is basically eliminated, particularly important in the food industry.
- The welded bar creates a flat, finished splice so belt "wave" is eliminated.
- Under abusive applications, Unibar spreads shock loads to protect individual hooks.



Unibar fasteners can easily be cut to the appropriate length, or ordered in special lengths up to 60" (1500 mm). They are not recommended for bias splices, troughed belts where common bar breakage is a concern and where special metals are not available in Unibar configuration.

### 430 STAINLESS - WITHOUT PINS - 12" STRIPS - 12 STRIPS PER BOX

| HOOK SIZE | Flexco Number | Westward Number | Wt. per Box (Lbs.) | Hooks per Card | Cards per Box | Lacing Inches Per Box |
|-----------|---------------|-----------------|--------------------|----------------|---------------|-----------------------|
| U2        | U2S12         | LAC2TS          | 1.2                | 84             | 12            | 144                   |
| U3        | U3S12         | LAC3TS          | 1.3                | 84             | 12            | 144                   |
| U4        | U4S12         | LAC4TS          | 1.7                | 84             | 12            | 144                   |

### STAINLESS STEEL™ - WITHOUT PINS - 12" STRIPS - 12 STRIPS PER BOX

| HOOK SIZE | FLEXCO NUMBER | WESTWARD NUMBER | WT. PER BOX (LBS.) | HOOKS PER CARD | CARDS PER BOX | LACING INCHES PER BOX |
|-----------|---------------|-----------------|--------------------|----------------|---------------|-----------------------|
| UCM36 XSP | UCM36SS12     | LAC01309        | 1.0                | 120            | 12            | 144                   |
| UCM36 SP  | 01314         | LAC01314        | 0.8                | 120            | 12            | 144                   |

### COATED STEEL™ - WITHOUT PINS - 12" STRIPS - 12 STRIPS PER BOX

| HOOK SIZE | Flexco Number | Westward Number | Wt. per Box (Lbs.) | Hooks per Card | Cards per Box | Lacing Inches Per Box |
|-----------|---------------|-----------------|--------------------|----------------|---------------|-----------------------|
| U2        | U2C12         | LAC2T           | 1.2                | 84             | 12            | 144                   |
| U3        | U3C12         | LAC3T           | 1.3                | 84             | 12            | 144                   |
| U4        | U4C12         | LAC4T           | 1.7                | 84             | 12            | 144                   |
| U5        | U5C12         | LAC5T           | 1.8                | 84             | 12            | 144                   |
| U6        | U6C12         | LAC6T           | 1.9                | 84             | 12            | 144                   |

### COATED STEEL™ - WITHOUT PINS - 24" STRIPS - 10 STRIPS PER BOX

| HOOK SIZE | Flexco Number | Westward Number | Wt. per Box (Lbs.) | Hooks per Card | Cards per Box | Lacing Inches Per Box |
|-----------|---------------|-----------------|--------------------|----------------|---------------|-----------------------|
| U2        | U2C24         | LAC2T-24        | 2.0                | 162            | 10            | 240                   |
| U3        | U3C24         | LAC3T-24        | 2.2                | 162            | 10            | 240                   |
| U4        | U4C24         | LAC4T-24        | 2.5                | 162            | 10            | 240                   |

### COATED STEEL™ - WITHOUT PINS - 12" STRIPS - 10 STRIPS PER BOX

| HOOK SIZE | Flexco Number | Westward Number | Wt. per Box (Lbs.) | Hooks per Card | Cards per Box | Lacing Inches Per Box |
|-----------|---------------|-----------------|--------------------|----------------|---------------|-----------------------|
| U3-1      | U3-1C24       | LACU3-1C24      | 2.2                | 162            | 10            | 240                   |

### COATED STEEL™ - WITHOUT PINS - 12" STRIPS - 12 STRIPS PER BOX

| HOOK SIZE | Flexco Number | Westward Number | Wt. per Box (Lbs.) | Hooks per Card | Cards per Box | Lacing Inches Per Box |
|-----------|---------------|-----------------|--------------------|----------------|---------------|-----------------------|
| U3-1      | U3-1C12       | LAC01138        | 1.3                | 84             | 12            | 144                   |

## CLIPPER POINT-OF-PURCHASE BALER BELT FASTENERS

### COATED STEEL™ - WITHOUT PINS - 12" STRIPS - 12 STRIPS PER BOX

| HOOK SIZE | Flexco Number       | Westward Number | Wt. per Box (Lbs.) | Hooks per Card | Cards per Box | Lacing Inches Per Box |
|-----------|---------------------|-----------------|--------------------|----------------|---------------|-----------------------|
| 7"        | 4-1/2RHTX(45)-10POP | LAC01847        | 0.5                | 45             | 4             | 28                    |



## CONNECTING PINS

Connecting pins are the vital link that combined with properly selected and installed hooks, completes the perfect splice. They are available in a wide range of materials and sizes as indicated in the chart below.



### CONNECTING PIN TYPES

- A. DuraStainless™ - DSS
- B. Duralink™ - DL
- C. Nylosteel - NY
- D. Nylostainless - NYS
- E. Nylon-Covered Cable - NCS
- F. Nylon Plus - NP



### STEPS TO SELECTING THE PROPER CONNECTING PIN

1. Determine the Diameter - Referring to the chart on page 26, select the proper connecting pin diameter based on your hook size.
2. Select Pin Material - the type of material you choose for the connecting pin is based on the application and your preferences. See chart below for pin material characteristics.
3. Specify Pin Length - Connecting pins can be ordered in coil lengths, Pin Packs™ or pre-cut lengths.

### PIN PACK™

Pin Pak™ is unique, all-in-one dispensing system that contains 100' (30 m) of spooled connecting pin material. It is available in most popular sizes and materials.

### CONNECTING PIN ORDER EXAMPLE

- STEP 1** Assume your hook size is UX1. Using the chart below, you see that UX1 hooks require a connecting pin with a .065" (1.7 mm) diameter.
- STEP 2** In this example, the application requires a rigid pin with high wear characteristics. Durastainless pin material is the best choice since it has a rigid 316SS spring wire core with a wear-resistant nylon covering.
- STEP 3** For ease of use, select the .065" (1.7 mm) Durastainless Pin Pak™. This allows you to easily remove the appropriate amount from the dispensing unit and conveniently store the remaining material for your next splice.

## CONNECTING PIN SPECIFICATIONS

| PIN DIAMETER SIZES | .065" (1.7 mm)            | .093 (2.4 mm)                | .109" (2.8 mm) | .125" (3.2 mm) | .156" (4.0 mm) |
|--------------------|---------------------------|------------------------------|----------------|----------------|----------------|
| HOOK SIZES         | 25, 30, 36, 1, UX1, UCM36 | 2SP, 2, 3, U2SP-U3, UA2, UA3 | 4, U4          | 4 1/2, 5, U5   | 6, 7, U6, U7   |

## CONNECTING PIN CHARACTERISTICS

| Connecting Pin Types      | Available Sizes                          |                                   | Abrasion Resistance | Hook Loop Wear Resistance | Rigidity | Magnetic | Flexibility | Composition   |
|---------------------------|--|-----------------------------------|---------------------|---------------------------|----------|----------|-------------|---|
|                           | in.                                      | mm                                |                     |                           |          |          |             |   |
| DuraStainless™ (DSS)      | .065, .093, .109                         | 1.7, 2.4, 2.8                     | Excellent           | Excellent                 | Good     | Slightly | Good        | Wear-resistant nylon & 300 Series Stainless spring wire |
| Duralink™ (DL)            | .065, .093, .109, .125                   | 1.7, 2.4, 2.8, 3.2                | Excellent           | Excellent                 | Average  | Slightly | Excellent   | Wear-resistant nylon & 300 Series Stainless cable       |
| Nylosteel (NY)            | .053, .065, .079, .093, .109, .125, .156 | 1.4, 1.7, 2.0, 2.4, 2.8, 3.2, 4.0 | Good                | Good                      | Good     | Yes      | Good        | Nylon & music wire                                      |
| Nylostainless (NYS)       | .053, .065, .079, .093, .109, .125, .156 | 1.4, 1.7, 2.0, 2.4, 2.8, 3.2, 4.0 | Good                | Good                      | Good     | Slightly | Good        | Nylon & 300 Series Stainless spring wire                |
| Nylon-Covered Cable (NCS) | .065, .093, .125, .156                   | 1.7, 2.4, 3.2, 4.0                | Good                | Good                      | Average  | Slightly | Excellent   | Nylon & 300 Series Stainless cable                      |
| Nylon Plus (NP)           | .053, .065, .079, .093, .109, .125, .156 | 1.4, 1.7, 2.0, 2.4, 2.8, 3.2, 4.0 | Good                | Excellent                 | Fair     | No       | Excellent   | Nylon   |

## CONNECTING PINS

### SPECIFICATIONS

| PIN DIAMETER SIZES | .065" (1/16") 1.7 mm (previously #25) | .0093" (3/32") 2.4 mm (previously #13) | .109" (7/64") 2.8 mm (previously #12) | .125 (1/8") 3.2 mm (previously #11) | .156" (5/32") 4.0 mm (previously #9) |
|--------------------|---------------------------------------|--|---------------------------------------|-------------------------------------|--------------------------------------|
|--------------------|---------------------------------------|--|---------------------------------------|-------------------------------------|--------------------------------------|

### PIN PAK™ 100 (100 FT. OF CONNECTING PIN WITH DISPENSER)

| PIN DIAMETER        | FLEXCO PART NO. | WESTWARD PART NO. | WT. LBS. |
|---------------------|-----------------|-------------------|----------|
| NYLOSTEEL           |                 |                   |          |
| .053                | NY053-C         |                   | 1.6      |
| .065                | NY065-C         | LAC02598          | 1.6      |
| .079                | NY079-C         | LACNW200C         | 1.8      |
| .093                | NY093-C         | LAC02628          | 2.0      |
| .109                | NY109-C         | LAC02622          | 2.1      |
| .125                | NY125-C         | LAC02614          | 2.2      |
| .156                | NY156-C         | LAC02607          | 2.5      |
| DURALINK            |                 |                   |          |
| .093                | DL093-C         | LAC02743          | 2.1      |
| .109                | DL109-C         | LAC02737          | 2.2      |
| .125                | DL125-C         |                   | 2.3      |
| NYLOSTAINLESS       |                 |                   |          |
| .053                | NYS053-C        |                   | 1.6      |
| .065                | NYS065-C        |                   | 1.6      |
| .079                | NYS079-C        |                   | 1.8      |
| .093                | NYS093-C        | LAC02670          | 2.0      |
| .109                | NYS109-C        | LAC02664          | 2.1      |
| .125                | NYS125-C        |                   | 2.2      |
| .156                | NYS156-C        |                   | 2.5      |
| NYLON COVERED CABLE |                 |                   |          |
| .053                | N/A             | N/A               |          |
| .065                | NC065-C         | LAC02751          | 1.7      |
| .079                | N/A             | N/A               |          |
| .093                | NCS093-C        | LAC02767          | 1.7      |
| .109                | N/A             | N/A               |          |
| .125                | NCS125-C        | LAC02762          | 3.0      |
| .156                | NCS156-C        |                   | 3.3      |



### CONNECTING PINS BY THE FOOT

| PIN DIAMETER        | FLEXCO PART NO. | WESTWARD PART NO. |
|---------------------|-----------------|-------------------|
| NYLON PLUS          |                 |                   |
| .079                | NP079-C         | LACNP079-C        |
| .093                | NP093-C         |                   |
| .109                | NP109-C         | LACNP109-C        |
| .125                | NP125-C         |                   |
| NYLON COVERED CABLE |                 |                   |
|                     | N/A             | N/A               |
| .093                | NCS903-C        |                   |
|                     | N/A             | N/A               |
| .125                | NCS125-C        |                   |

### PRECUT CONNECTING PIN

| PART NO. | LENGTH |
|----------|--------|
| LAC02622 | 7"     |



**ALLIGATOR® RIVET FASTENING SYSTEM**

Alligator Rivet is a strong, easy-to-install splice for round hay baler applications.

Alligator Rivet offers easy installation and low cost - without sacrificing reliability and long life. These advantages improve baler performance, bottom-line costs and overall productivity.

The fasteners, rivets and connecting pins are made of strong, abrasion-resistant stainless steel. Additionally, the fastener's leading edge has a low-profile - this avoids snagging and minimizes wear on other components, such as rollers. Alligator Rivet is also compatible with net wrap balers.

**EASY, ON-SITE INSTALLATION AT A LOWER COST**

The Alligator Rivet Splice is easier to install - and less costly - than other competitive brands. And, without ever removing the belts from the baler, field installation is quick and easy with only the portable application tool and a 1 lb. hammer.

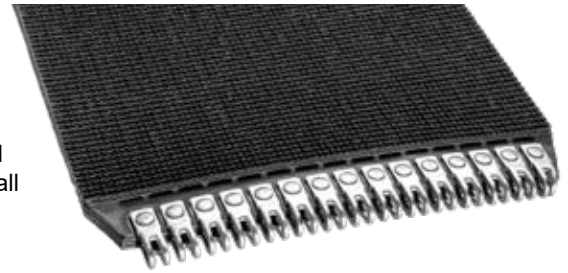

**HIGH STRENGTH AND LONGER LIFE**

Rugged, stainless steel design is abrasion and corrosion resistant and has a long life for severe, heavy-duty applications.

Fasteners are available in 4", 7", 10" and 14" (100 mm, 175 mm, 250 mm and 350 mm) pre-cut lengths, and can be cut to shorter lengths.



Self-setting rivets accommodate belt thickness 1/8" to 7/32" (3.2 mm to 5.6 mm) thick. They can be applied to all types of baler belting, including used belts.



The connecting pin is designed for long life. It is a large diameter (.140" or 3.6 mm) hardened spring, stainless steel material.



For field installation, all that's required is the applicator tool and a 1 lb. hammer - special punches are not required.



You never have to remove the belt from the baler.

## ALLIGATOR® RIVET FASTENERS

### FASTENERS

Includes fasteners, rivets and hinge pins for 2 complete splices.

| BELT WIDTH |        | WESTWARD PART NO. | ITEM CODE | UNIT OF MEASURE |
|------------|--------|-------------------|-----------|-----------------|
| 4"         | 100 mm | LACAR-4           | 15000     | Package         |
| 6"         | 150 mm | LACAR-6           | 14995     | Package         |
| 7"         | 175 mm | LACAR-7           | 15001     | Package         |
| 10"        | 250 mm | LACAR-10          | 15002     | Package         |
| 14"        | 350 mm | LACAR-14          | 15003     | Package         |



### APPLICATOR TOOLS

| DESCRIPTION                    | WESTWARD PART NO. | ITEM CODE |
|--------------------------------|-------------------|-----------|
| 7" (175 mm) installation tool  | LCRART-7          | 15004     |
| 14" (350 mm) installation tool | LCRART-14         | 15005     |



### REPLACEMENT PARTS FOR APPLICATOR TOOLS

| DESCRIPTION                              | WESTWARD PART NO. | ITEM CODE |
|--|-------------------|-----------|
| Alligator Rivet Tool Cam Lever Assembly  | LCR15012          | 15012     |
| 7" Alligator Rivet Guide Block           | LCRMARGB-7        | 15028     |
| Alligator Rivet Guide Block Knob         | LCRMART-GBK       | 15030     |
| Cam Lever Assembly Replacement For ART-7 | LACN1914          | N1914     |
| Spring Compression SRT-5 ZP for ART-7    | LACP0105          | P0105     |

### PNEUMATIC PUNCH FOR ALLIGATOR RIVET TOOL

NOTE: When using the pneumatic punch, air pressure not to exceed 85 psi.

| DESCRIPTION     | WESTWARD PART NO. | ITEM CODE |
|-----------------|-------------------|-----------|
| Pneumatic Punch | LACAR1P           | 15027     |



### COMPLETE TOOL KITS

Each kit includes an installation tool, belt hand skiver, 1 lb. hammer, pin bender and 2 packages of Alligator rivets. Packaged in durable plastic tool box.

| DESCRIPTION                    | WESTWARD PART NO. | ITEM CODE | WT. LBS. |
|--------------------------------|-------------------|-----------|----------|
| 7" (175 mm) installation tool  | LCRARTK-7         | 15006     | 14.5     |
| 14" (350 mm) installation tool | LCRARTK-14        | 15015     | 18.5     |



## ALLIGATOR® RIVET FASTENERS

### REPLACEMENT HINGE PINS

300 Series Stainless Spring Wire Pin



| BELT WIDTH |     | WESTWARD PART NO. | ITEM CODE | QTY. PKG. | WESTWARD PART NO. | ITEM CODE | QTY. PKG. |
|------------|-----|-------------------|-----------|-----------|-------------------|-----------|-----------|
| INCHES     | mm  | ARSS1             |           |           | ARSG              |           |           |
| 4          | 100 | LACARSS1-4/100    | 15007     | 9         | LACARSH4/100      | 14990     | 9         |
| 6          | 150 | LACARSS1-6/150    | 15017     | 8         | -                 | 14991     | 8         |
| 7          | 175 | LACARSS1-7/175    | 15008     | 8         | LACARSH7/175      | 14992     | 8         |
| 10         | 250 | LACARSS1-10/250   | 15009     | 4         | LACARSH10/250     | 14993     | 4         |
| 14         | 350 | LACARSS1-14/350   | 15010     | 4         | LACARSH14/350     | 14994     | 4         |

### ALLIGATOR HINGE PIN BENDER

For use with spring wire pins

| WESTWARD NO. | DESCRIPTION                | ITEM CODE |
|--------------|----------------------------|-----------|
| LCRPB1       | Alligator Hinge Pin Bender | 50077     |



### EXTRA RIVETS

| DESCRIPTION | WESTWARD PART NO. | ITEM CODE |
|-------------|-------------------|-----------|
| 15/PKG.     | LACAR3-15         | 15011     |



| OPERATING TENSION RANGE |      | BELT THICKNESS RANGE |           | PULLEY DIAMETER |    | APPROX. HINGE PIN |     |
|-------------------------|------|----------------------|-----------|-----------------|----|-------------------|-----|
| P.I.W.                  | kN/M | Inch                 | mm        | Inch            | mm | Inch              | mm  |
| 300                     | 52   | 1/8 - 7/32           | 3.2 - 5.6 | 3 1/2           | 88 | .140              | 3.6 |

## HEAVY PLATE (MATO) STYLE LACING AND ACCESSORIES

### MATO "U" TOOLS AND ACCESSORIES

| PART NUMBER  | DESCRIPTION   |
|--------------|---|
| LAC411295862 | U24BS Heavy Plate 14 Segment Used for 7" John Deere Baler Belts |
| LAC411295807 | MATO Hex Shank Punch for Air Hammer                             |
| LAC411295825 | Hand Punch  |
| LAC411295827 | 18mm Belt Skiver  |
| LCR411295869 | 07 U20 Prof-14 Used for 7" John Deere Baler Belts               |
| LCR411295828 | Replacement Blades for Belt Skiver (5/pkg)                      |

### MATO "H" TOOLS AND ACCESSORIES

| PARTNUMBER   | DESCRIPTION   |
|--------------|---|
| LCR411296961 | 7" H24 Profi Installation Field Tool Continuous Lacing Capabilities Wider than 7" |
| LAC411156069 | H24BS 14 Segment Used for 7" John Deere Baler Belts                               |
| LAC411296963 | 7" H24 Eco Field Tool   |

| PARTNUMBER | DESCRIPTION   |
|------------|---|
| BEL1701433 | Pin Notched Spring Steel 6.5" (for John Deere 7" belts) |

## TITAN STYLE FASTENERS & ACCESSORIES

| WESTWARD NO. | DESCRIPTION  |
|--------------|--|
| LAC109201    | 7" Vice Installation Tool                                  |
| LAC1701491   | Titan 05 Plates for 7" Belts<br>12 Cards per Box with Pins |
| LAC1701565   | Titan 05 Stainless Steel 6.375" Pin                        |
| BEL1701540   | Nylon conversion cable - 25' coil for Titan                |

## ALLIGATOR® READY SET™ STAPLE FASTENERS

The Ready Set staple system provides the same field-proven advantages of the traditional Alligator® staple line.

This new staked-staple concept is designed for your light and medium-duty material handling applications. With the Ready Set system, you always have the right size staples, in the right quantities.

With the Ready Set staple fastener system, an extended plate design separates the point of staple penetration from the line of belt flexing, thus eliminating splice fatiguing that results from sawing action at the point of attachment.



High tensile, stainless steel staple fasteners are furnished in strips with a bridge between each fastener plate. This strip design prevents individual parts from getting into the product being conveyed - eliminating a problem that may occur with some hook or teeth types of fasteners. The Ready Set staples provide a strong splice, resistance to impact damage, and a smooth, unripped joint that makes hinge pin insertion easier.

Ready-Set staples work between carcass fibers without severing them. Staples are hammer-driven through the belt, then clinched cross-wise to the belt, so that belt tension does not pull against the staples to unclinch them.

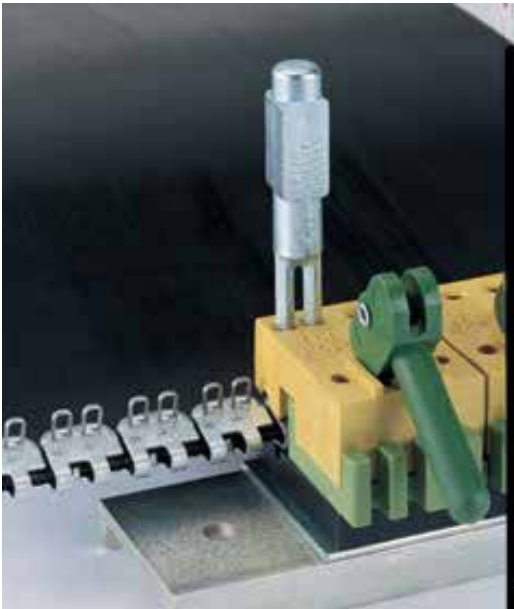

### QUICK AND EASY INSTALLATION!

Ready Set™ staple conveyor belt fasteners reduce your installation step.

One piece fastener strips arrive with staples pre-inserted in each fastener's top plate. So you never need to load a staple dispenser or manually insert individual loose staples into an installation tool.

Simply fit the fastener strip onto the belt ends and secure in the special installation tool, then drive and finish set the staples for a strong, long-lasting splice.

The RSC187 installation tool holds fasteners securely on the belt, in proper alignment, while staples are driven. The tool also provides an anvil surface for initial clinching of the staples.

*With the RSC187 tool, you can accurately install two staples simultaneously for quick, dependable splice installation.*

*As light as 6 lbs., these tools can be easily carried to the belt. Only one installation tool and a hammer are needed to complete a splice.*

**READY SET™ STAPLE FASTENERS -RSC187 TOOL**

The RSC187 tool accurately installs two staples simultaneously for quick, dependable splice installation. No. RS62, No. RS125 and No. RS187 fasteners are each installed with the Series RSC187 tool. Tools come complete with guide blocks and driver. RSC187 tools are available in a variety of sizes which allow varying amounts of belt width to be laced at one position. Tools can be moved rapidly along the belt as staples are installed. Tools up to 12" wide, speed splicing. Wider tools are available for production lacing and fabrication shop requirements.

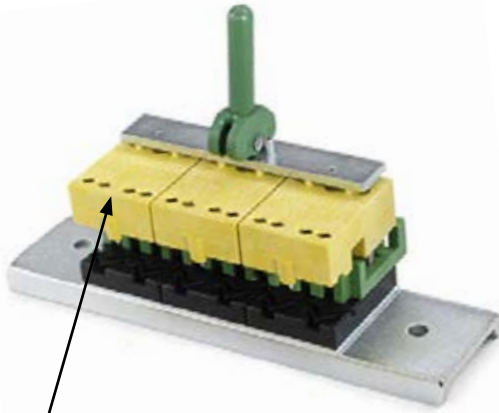

**Attention Users of Traditional Alligator® Staple**  
 Conversion to Alligator Ready Set is easy. Simply replace your current guide block(s) with the new ST5-5 staple guide block(s).  
 Order Number: LCRST5-5  
 Item Code: 50016

**INSTALLATION TOOLS**

| WESTWARD PART NO. | ITEM CODE |
|-------------------|-----------|
| LCRRSC187-2       | 54626     |
| LCRRSC187-4       | 54627     |
| LCRRSC187-6       | 54628     |
| LCRRSC187-12      | 54629     |
| LCRRSC187-24      | 54631     |

**RSC187 ACCESSORIES**

| WESTWARD PART NO. | DESCRIPTION                   | ITEM CODE |
|-------------------|-------------------------------|-----------|
| LCRST3-9          | RSC187 Staple Driver          | 50200     |
| LCRST4-8          | 8" Cam Lever Assembly - Longt | 50243     |
| LCRST5-5          | 2" Staple Guide Block         | 50016     |
| LCRST5-16         | RSC187 Comb 62/125 (Yellow)   | 54010     |
| LCRST-28          | Readyset Staple Setting Plate | 50249     |



LCRST5-5



LCRST3-9

**APPLICATIONS**

Light and medium-duty conveyor belts in package and baggage handling, cased goods, parts, food, wood and agricultural products.

**INSTALLATION METHOD**

A portable, lightweight application tool can be easily carried to the job site. This tool holds the belt and fastener while staples are driven with a hammer.

**FASTENER PROFILE**

Smooth, low profile facilitates operation with diverters and shears.

**PIW (Pounds per inch width)**

For belts with mechanical fastener rating up to 200 PIW or 35 kN/m.

**PULLY DIAMETER**

Alligator Ready Set staple fasteners operate smoothly over pulleys as small as 2" (50 mm) in diameter.

**METALS AVAILABLE**

Steel - Type 316 Stainless Steel

**RANGE**

For belts from 1/16" (1.5 mm) to 1/4" (6.4 mm) thick.



**COMPLETE STAPLE KIT**

Everything you need to install, maintain and repair No. RS62, No. RS125 and No. RS187 Alligator staple belt splices. Lightweight, only 16 1/2 lbs. Kit includes a RSC187 installation tool, staple set plate, hand skiver, belt marker, belt nippers and a 1 lb. hammer. All packaged in a durable metal box with plenty of room left over for other items.

| WESTWARD PART NO. | ITEM CODE | DESCRIPTION         |
|-------------------|-----------|---------------------|
| LCRRSTK4-6        | 54634     | 6" Installation Kit |

## ALLIGATOR® READY SET™ STAPLE CONVEYOR BELT FASTENERS

### FASTENER SIZES

A variety of fastener sizes and metals are available for joining belts in a wide range of light to medium-duty applications. Typical applications include package and parts handling, agricultural and food processing conveyors.



#### No. RS62

- For belts 1/16" (1.5 mm) to 1/8" (3.2 mm) thick.
- Operates on a minimum pulley diameter of 2" (50 mm) or larger.
- For use on belts with mechanical fastener ratings up to 100 PIW or 175 kN/m.
- Available in Type 316 Stainless Steel and Plated Steel.
- Will couple with No. RS125 for belt ends of slightly different thicknesses, using No. RS62 hinge pin, as long as the minimum pulley diameter for No. RS125 is met.



#### No. RS125

- For belts 1/8" (3.2 mm) to 3/16" (4.8 mm) thick.
- Operates on a minimum pulley diameter of 3" (75 mm) or larger.
- For use on belts with mechanical fastener ratings up to 160 PIW or 28 kN/m.
- Available in Type 316 Stainless Steel and Plated Steel.
- Belt end of slightly different thicknesses can be joined. No. RS125 and No. RS187 can be joined using a No. RS125 hinge pin, as long as the minimum pulley diameter for No. RS187 is met.

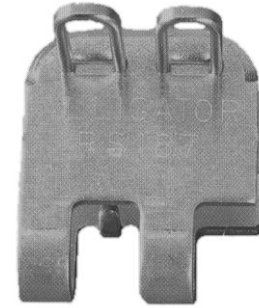

#### No. RS187

- For belts 3/16" (4.8 mm) to 1/4" (6.4 mm) thick.
- Operates on a minimum pulley diameter of 4" (102 mm) or larger.
- For use on belts with mechanical fastener ratings up to 200 PIW or 35 kN/m.
- Available in Type 316 Stainless Steel and Plated Steel.

### HOW TO SPECIFY THE RIGHT ALLIGATOR READY SET STAPLE FASTENER

#### A. DETERMINE YOUR BELT TENSION

Most conveyor belting has a mechanical fastener rating. The fastener sizes listed above are for use on belts with ratings not in excess of the values shown. Belting and fasteners should not be operated beyond the recommended ratings.

#### B. MEASURE YOUR BELT THICKNESS

If fasteners are to be countersunk, measure the belt thickness after a portion of the belt cover has been removed. Choose a fastener size which corresponds to the belt thickness in this countersunk area.

#### C. MEASURE THE DIAMETER OF THE SMALLEST PULLEY IN YOUR DRIVE

*Note minimum pulley diameters shown for various fasteners.*

#### D. CHOOSE THE FASTENER SIZE THAT IS APPROPRIATE FOR YOUR SPECIFICATIONS.

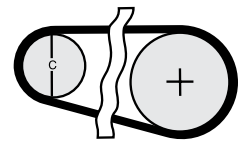

### READY SET STAPLE FASTENER SELECTION CHART

| FASTENER SIZE NO. | A   |      | B                    |           | C                           |     |
|-------------------|---|------|----------------------|-----------|-----------------------------|-----|
|                   | FOR BELTS WITH MECHANICAL FASTENER RATINGS UP TO: |      | BELT THICKNESS RANGE |           | RECOMMENDED PULLEY DIAMETER |     |
|                   | PI.W.   | kN/m | in.                  | mm        | in.                         | mm  |
| RS62              | 100   | 17   | 1/16 - 1/8           | 1.5 - 3.2 | 2                           | 50  |
| RS125             | 160   | 28   | 1/8 - 3/16           | 3.2 - 4.8 | 3                           | 75  |
| RS187             | 200   | 35   | 3/16 - 1/4           | 4.8 - 6.4 | 4                           | 102 |

**ALLIGATOR® READY SET™ STAPLE SYSTEM**



The Alligator® Ready-Set Staple Fastening System speeds installation, keeping downtime to a minimum. With pre-inserted staples and a one-piece strip design, Alligator® Ready Set™ makes splicing quick and easy.

- Strong and impact-resistant splice
- Abrasion resistant splice
- The front edge of the fastener is beveled to allow it to interface smoothly with conveyor components. Available in steel & stainless steel



**RS62 ALLIGATOR®**

RS62 is ideal for systems with a minimum pulley diameter of 2" (50 mm) and belt thicknesses ranging from 1/16" to 1/8" (1.5 mm to 3.2 mm).

- Design: One-piece fastener strip with pre-inserted staples
- Belt Thickness: 1/16" to 1/8" (1.5 mm to 3.2 mm)
- Minimum Pulley Diameter: 2" (50 mm)
- Maximum PIW: 100 (17 kN/m)
- Installation Method: Hammer or power tool and installation tool



| PART NUMBER   | BELT WIDTH | DESCRIPTION              | MFR. NO | WEIGHT |
|---------------|------------|--------------------------|---------|--------|
| LACRS062J24NC | 24"        | BOX OF 4 READYSET JOINTS | 54480   | 2.7    |

**RS125 ALLIGATOR®**

RS125 is ideal for systems with a minimum pulley diameter of 3" (75 mm) and belt thicknesses ranging from 1/8" to 3/16" (3.2 mm to 4.8 mm).

- Design: One-piece fastener strip with pre-inserted staples
- Belt Thickness: 1/8" to 3/16" (3.2 mm to 4.8 mm)
- Minimum Pulley Diameter: 3" (75 mm)
- Maximum PIW: 160 (28 kN/m)
- Installation Method: Hammer or power tool and installation tool



| PART NUMBER     | BELT WIDTH | DESCRIPTION                   | MFR. NO | WEIGHT |
|-----------------|------------|-------------------------------|---------|--------|
| LACRS125J12NC   | 12"        | BOX OF 4 READYSET JOINTS      | 54515   | 1.9    |
| LACRS125J16NC   | 16"        | BOX OF 4 READYSET JOINTS      | 54517   | 2.5    |
| LACRS125J16NCS  | 16"        | BOX OF 4 READYSET JOINTS      | 54552   | 2.5    |
| LACRS125J18NC   | 18"        | BOX OF 4 READYSET JOINTS      | 54518   | 2.8    |
| LACRS125SJ18SS  | 18"        | BOX OF 4 READYSET JOINTS - SS | 54540   | 3.0    |
| LACRS125J20NCS  | 20"        | BOX OF 4 READYSET JOINTS      | 54554   | 3.3    |
| LACRS125SJ20SS  | 20"        | BOX OF 4 READYSET JOINTS - SS | 54541   | 3.5    |
| LACRS125J24NC   | 24"        | BOX OF 4 READYSET JOINTS      | 54529   | 3.7    |
| LACRS125SJ24NCS | 24"        | BOX OF 4 READYSET JOINTS      | 54555   | 3.8    |
| LACRS125SJ24SS  | 24"        | BOX OF 4 READYSET JOINTS - SS | 54542   | 3.9    |
| LACRS125J30NC   | 30"        | BOX OF 4 READYSET JOINTS      | 54521   | 4.5    |
| LACRS125J36NC   | 36"        | BOX OF 4 READYSET JOINTS      | 54522   | 5.5    |
| LACRS125J48NC   | 48"        | BOX OF 4 READYSET JOINTS      | 54524   | 7.4    |
| LACRS125SJ48SS  | 48"        | BOX OF 4 READYSET JOINTS - SS | 54545   | 8.0    |
| LACRS125J60NC   | 60"        | BOX OF 4 READYSET JOINTS      | 54525   | 9.3    |

**RS187 ALLIGATOR®**

RS187 is ideal for systems with a minimum pulley diameter of 4" (102 mm) and belt thicknesses ranging from 3/16" to 1/4" (4.8 mm to 6.4 mm).

- Design: One-piece fastener strip with pre-inserted staples
- Belt Thickness: 3/16" to 1/4" (4.8 mm to 6.4 mm)
- Minimum Pulley Diameter: 4" (102 mm)
- Maximum PIW: 200 (35 kN/m)
- Installation Method: Hammer or power tool and installation tool



| PART NUMBER   | BELT WIDTH | DESCRIPTION              | MFR. NO. | WEIGHT |
|---------------|------------|--------------------------|----------|--------|
| LACRS187J12NC | 12"        | BOX OF 4 READYSET JOINTS | 54588    | 2.6    |
| LACRS187J24NC | 24"        | BOX OF 4 READYSET JOINTS | 54592    | 5.5    |
| LACRS187J36NC | 36"        | BOX OF 4 READYSET JOINTS | 54594    | 8.1    |
| LACRS187J48NC | 48"        | BOX OF 4 READYSET JOINTS | 54596    | 9.9    |

## READY SET™ STAPLE CONVEYOR BELT FASTENERS

### ALLIGATOR® READY SET™ HINGE PINS

| PART NUMBER    | BELT WIDTH | DESCRIPTION                            | MFR. NO. |
|----------------|------------|--|----------|
| LACARSH7/175   | 7"         | Hinge Pins - Steel Corrugated 8/pk     | 14992    |
| LACARSS1-7/175 | 7"         | Hinge Pins - Sainless Spring Wire 8/pk | 15008    |



### ALLIGATOR® READY SET™ HINGE PINS (COILS AND REELS)

#### NC-Nylon Covered Steel Cable

Galvanized steel cable strands are protected by a nylon covering which lubricates fastener loops and helps to hold the pin in place.

#### NCS-Nylon Covered Stainless Steel Cable

Nylon coated 300 Series stainless cable resists corrosion. Not recommended in deep troughing applications over 35°.

#### SP-Steel Spring Wire

Steel Spring Wire is ideal for flat bed conveyors carrying abrasive or gritty material.

#### SS-Stainless Steel Spring Wire

For use with stainless steel fasteners on flat belt conveyors 14" and wider.

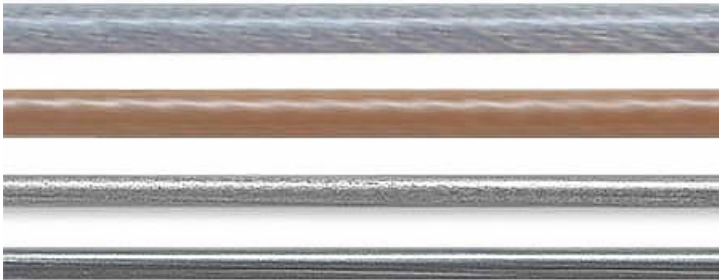

| COIL  |    | WESTWARD PART NO. | ITEM CODE |
|---|----|-------------------|-----------|
| FT  | M  |                   |           |
| For Staple No. RS62, NC62 Nylon-Covered Steel Cable     |    |                   |           |
| 10  | 3  | LACNC62-X         | 54002     |
| 100   | 30 | LACNC62-C         | 54003     |
| For Staple No. RS125, NC1 Nylon-Covered Steel Cable     |    |                   |           |
| 10  | 3  | LACNC1-X          | 50661     |
| 100   | 30 | LACNC1-C          | 50662     |
| For Staple No. RS125, NC1 Nylon-Covered Steel Cable     |    |                   |           |
| 10  | 3  | LACNC187-X        | 50669     |
| 100   | 30 | -                 | 50670     |
| For Staple No. RS125, NC1 Nylon-Covered Stainless Cable |    |                   |           |
| 10  | 3  | LACNC1S-X         | 50665     |
| 100   | 30 | LACNCS1-C         | 50666     |

### EXTRA HINGE PIN RETAINING WASHERS

Prevent Pin Migration with Hinge Pin Retaining Washers. (50 per package)

| FASTENER SIZE | WESTWARD PART NO. | ITEM CODE |
|---------------|-------------------|-----------|
| 62            | LAC62RET50        | 54030     |
| 125           | LAC125RET50       | 50053     |
| 187           | LAC187RET50       | 50075     |





## ALLIGATOR® LACING

### APPLICATIONS

Manufacturing assembly lines, food, package and parts handling, checkout counters and agricultural equipment.

### INSTALLATION METHOD

Requires only a hammer; no special tools needed. Unique, patented clips and round gauge rod act as an "extra pair of hands." For production splicing, Alligator belt lacing machines are offered.

### FASTENER PROFILE

Low profile, one-piece design results in an exceptionally smooth joint.

P.I.W. (pounds per inch width)

Use with belts that are mechanically rated up to 200 PIW or 35 kN/m (maximum recommended tension range varies by lacing size).

### PULLEY DIAMETER RANGE

Alligator lacing is a continuous one-piece fastener strip, tailored to all standard belt widths. Lacing is secured with teeth that imbed lengthwise on the belt, providing a strong, vise-like attachment.

### METALS AVAILABLE

Steel - Steel is the standard fastener material.

Stainless Steel - Type 316 Stainless Steel.

Monel® - A nickel and copper alloy.

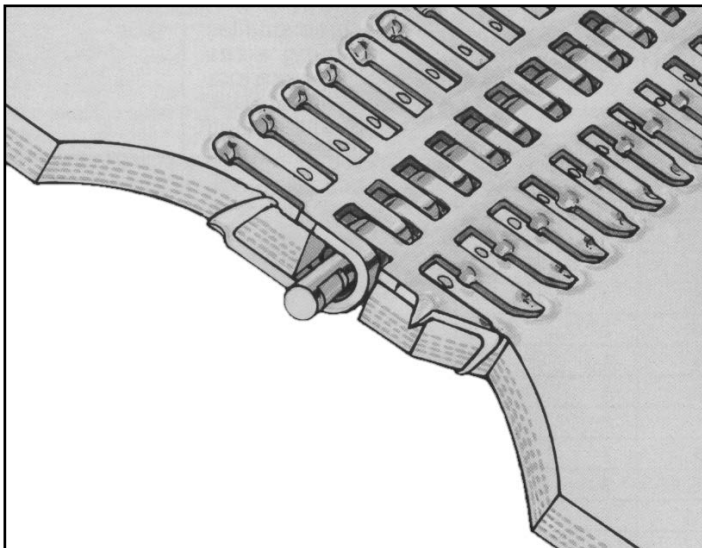
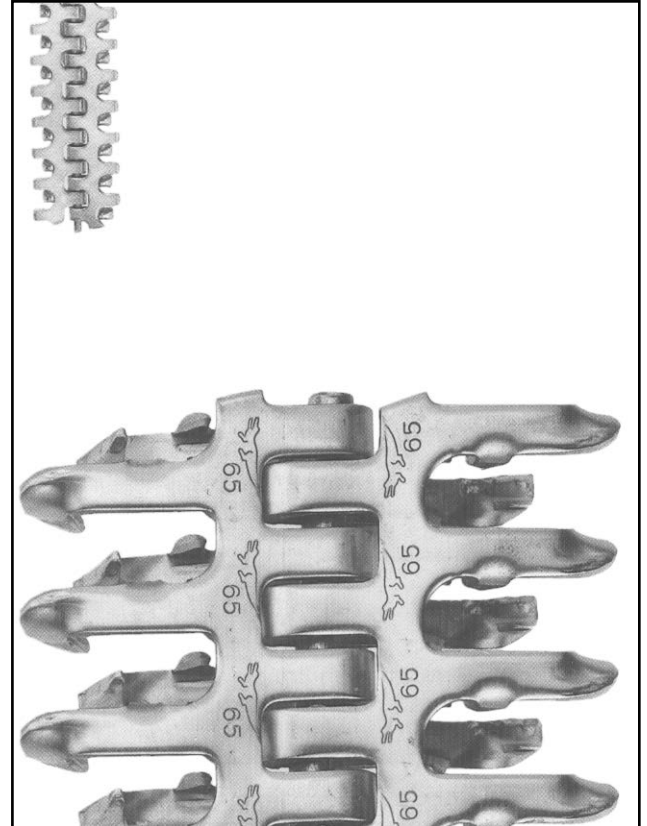

## How Alligator® Lacing Works

Alligator Lacing utilizes a design with teeth that enter parallel to the length of the belt and imbed clear through the belt carcass. The teeth are formed so that when they are driven into the belt, the vital longitudinal carcass fibers are not severed.

Additional strength is obtained due to the connecting bar and because the fastener strip is one continuous piece. This provides a strong, viselike hold on the belt and distributes belt tension evenly across the centre belt width. The one-piece fastener strip also insures that there are no loose pieces to work themselves out of the belt and into the conveyed product. The straight splice obtained with a continuous strip of lacing also helps with hinge pin insertion.

## ALLIGATOR® LACING

### HOW TO SPECIFY THE RIGHT ALLIGATOR LACING

- Determine your belt tension. Most conveyor belting has a mechanical fastener rating. The fastener sizes listed in the chart below are for use on belts with ratings not in excess of the values shown. Care should be taken to not operate the belting or fasteners beyond their recommended ratings.
- Measure your belt thickness. If a portion of the belt cover is to be removed to "recess" the lacing, measure the belt thickness after skiving or grinding has taken place. Choose a lacing size which corresponds to the belt thickness.
- Measure the diameter of the smallest pulley in your drive. Note minimum pulley diameters shown for various sizes of lacing in the chart below.
- Choose the fastener size that is appropriate for your specifications in the chart below.

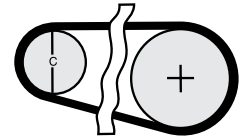

## FASTENER TYPES & SIZES

There are two types of Alligator® Belt Lacing. Alligator® Conveyor Belt Lacing and Alligator® Transmission Belt Lacing.

### Conveyor Belt Lacing

For Flat Conveyor Belts from 12" or 300 mm to 60" or 1500 mm wide and for belts 1/32" or 8 mm to 1/2" or 13 mm thick use "Conveyor" Belt Lacing sizes No. 00 to No. 65. Standard hinge pin is corrugated of the same metal as the lacing. Other types of pins also available.



### Transmission Belt Lacing

For Flat Power Transmission Belts, up to 12" or 300 mm wide, use "Transmission" Belt Lacing sizes No. 00 to No. 65. Lacing is scored and can be broken off easily to fit narrower belts. Corrugated hinge pins are furnished with three smallest lacing sizes. Two-piece rocker hinge pins are furnished with sizes 15 to 65.



| LACING SIZE NO. | A   |      | B                    |             | C                                   |     |
|-----------------|---|------|----------------------|-------------|-------------------------------------|-----|
|                 | FOR BELTS WITH MECHANICAL FASTENER RATINGS UP TO: |      | BELT THICKNESS RANGE |             | RECOMMENDED MINIMUM PULLEY DIAMETER |     |
|                 | P.I.W.  | kN/m | in.                  | mm          | in.                                 | mm  |
| 0               | 25  | 4.3  | up thru 1/16         | up thru 1.6 | 1                                   | 25  |
| 1               | 45  | 7.8  | 1/16 - 3/32          | 1.6 - 2.4   | 1 1/2                               | 38  |
| 7               | 50  | 8.7  | 3/32 - 9/64          | 2.4 - 3.6   | 2                                   | 51  |
| 15              | 65  | 11.4 | 1/8 - 5/32           | 3.2 - 4.0   | 2 1/2                               | 64  |
| 20              | 95  | 16.6 | 5/32 - 3/16          | 4.0 - 4.8   | 3                                   | 76  |
| 25              | 100   | 17.5 | 3/16 - 7/32          | 4.8 - 5.6   | 4                                   | 102 |
| 27              | 100   | 16   | 7/32 - 9/32          | 5.6 - 7.1   | 5                                   | 127 |
| 35              | 150   | 26   | 9/32 - 5/16          | 7.1 - 7.9   | 7                                   | 178 |
| 45              | 165   | 28   | 5/16 - 3/8           | 7.9 - 9.5   | 9                                   | 229 |
| 55              | 175   | 30   | 3/8 - 7/16           | 9.5 - 11.1  | 12                                  | 305 |
| 65              | 200   | 35   | 7/16 - 1/2           | 11.1 - 12.7 | 14                                  | 356 |

## ALLIGATOR® LACING

Order Correct Lacing Type (Conveyor or Transmission Belt Lacing and Size, Metal and Hinge Pin)



## CONVEYOR BELT LACING CARTONS

Carton contains everything needed for 4 complete joints: 4 sets (joints) of lacing, 4 corrugated hinge pins and 1 installation gauge pin with clips.

| STEEL LACING CARTONS WITH STEEL CORRUGATED HINGE PINS ORDERING NUMBERS |                  |                   |           |
|--|------------------|-------------------|-----------|
| BELT WIDTH   | EQUIVALENT WIDTH | WESTWARD PART NO. | ITEM CODE |
| in.  | mm               |                   |           |
| FOR NO. 7  |                  |                   |           |
| 12   | 305              | -                 | 10090     |
| FOR NO. 15   |                  |                   |           |
| 16   | 406              | -                 | 10111     |
| 18   | 457              | -                 | 10112     |
| 20   | 508              | -                 | 10113     |
| 24   | 609              | LAC15X24          | 10115     |
| FOR NO. 20   |                  |                   |           |
| 18   | 457              | -                 | 10132     |
| FOR NO. 25   |                  |                   |           |
| 24   | 609              | -                 | 10155     |
| FOR NO. 27   |                  |                   |           |
| 24   | 609              | -                 | 10170     |
| 42   | 1066             | -                 | 10176     |
| 48   | 1219             | -                 | 10177     |

**CALL FOR AVAILABILITY ON SIZES  
AND MATERIALS NOT SHOWN.**



## TRANSMISSION BELT LACING BOXES



Boxes contain 12" or 300 mm lacing strips, (except No. 00, No. 1 and No. 7 which contain 6" or 150 mm) hinge pins and 1 gauge pin; 4 or 6 joints per box.

Transmission Belt Lacing is scored so it can be broken off easily to fit belts that are narrower than packaged size.

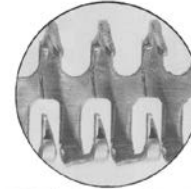

Transmission Belt Lacing



Conveyor Belt Lacing



Conveyor Belt Lacing has a "radius check" reference point to aid in shortening strips for narrower widths. Shortening is easily accomplished with a standard cold chisel or nippers.

| STEEL TRANSMISSION BELT LACING BOXES WITH STEEL CORRUGATED HINGE PINS |           |                |
|---|-----------|----------------|
| WESTWARD PART NUMBER  | ITEM CODE | JOINTS PER BOX |
| LAC1A   | 10001     | 6              |
| LAC7  | 10002     | 6              |
| LAC15   | 10003     | 4              |
| LAC20   | 10004     | 4              |
| LAC25D  | 10005     | 4              |
| LAC27K  | 10008     | 4              |
| -   | 10011     | 4              |
| LAC45U  | 10012     | 4              |
| -   | 10013     | 4              |

## TRANSMISSION BELT LACING ECONOMY CARTONS

Power Transmission Belt Lacing is available in economy cartons that include one lacing joint, one gauge pin and a steel, rocker hinge pin. Ten packages per carton. Five sizes to choose from.

| STEEL TRANSMISSION BELT LACING BOXES WITH STEEL ROCKER HINGE PINS ORDERING |           |                |
|--|-----------|----------------|
| WESTWARD PART NUMBER   | ITEM CODE | JOINTS PER BOX |
| LAC15E   | 10020     | 10             |
| -  | 10021     | 10             |
| -  | 10022     | 10             |
| -  | 10023     | 10             |
| -  | 10024     | 10             |



### INSTALLED WITH A HAMMER

Only a hammer and a firm surface is required to install Alligator® Lacing. On-site installation is quick and simple. No heavy equipment to haul around.

**FLEXCO® BOLT HINGED FASTENER SYSTEM**

For belts operating over smaller pulleys - such as in construction equipment and road machinery. Flexco Bolt Hinged Fasteners are strong, dependable and easy-to-install.

Designed as a compression fastener, Bolt Hinged is fastened to the belt ends with high tensile strength bolts. These compress the plates in the belt cover. Additional holding capability is provided by the fastener teeth that imbed in the belt without damage to the belt carcass. So splice tension is distributed across the entire plate width and teeth secure the fastener to resist pull-out.



**APPLICATION VERSATILITY**

Hinged construction makes Bolt Hinged fasteners ideal for many types of machinery that use smaller pulleys but still require a high-strength splice. And for applications requiring frequent belt-length alterations, the joint can be separated simply by removing the hinge pin.

**EASY INSTALLATION**

On-site installation requires only portable hand or power tools. A specially designed templet and boring tool or belt punch quickly and accurately punches bolt holes into belts. Installation is also simplified by our exclusive piloted bolt. Tapered bolt tips cradle nuts securely in place and eliminate the need to twist nuts onto bolts by hand during installation set-up.

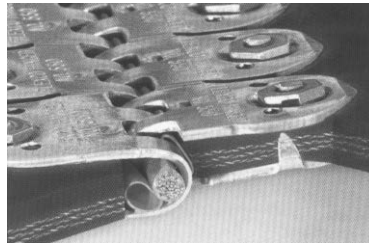

| FLEXCO® BOLT HINGED FASTENER SELECTION GUIDE |                      |        |   |      |   |     |
|--|----------------------|--------|---|------|---|-----|
| FASTENER SIZE                                | BELT THICKNESS RANGE |        | FOR BELTS WITH MECHANICAL FASTENER RATINGS UP TO: |      | RECOMMENDED MINIMUM PULLEY DIAMETER (OPERATING TENSION 75% - 100% OF BELT RATING) |     |
|  | in.                  | mm     | P.I.W.  | kN/m | in.   | mm  |
| 375X   | 1/4 - 13/32          | 6 - 11 | 190   | 33   | 6   | 150 |
| 550  | 1/4 - 5/8            | 6 - 16 | 300   | 52   | 9   | 225 |

**SELECTION CHARTS**

"J" carton complete fastener joint. Each "J" carton includes one complete belt joint for belt widths ranging from 12" (300 mm) to 60" (1500 mm).



Cartons include:

- 2 fastener strips
- 1 hinge pin
- Filler tubing
- 1 gauge pin
- 2 hinge pin washers
- Required piloted bolts, nuts, clips

| 375X FASTENERS                                |      |                   |
|---|------|-------------------|
| NC STEEL JOINT WITH NYLON COVERED STEEL CABLE |      |                   |
| BELT WIDTH                                    |      | WESTWARD PART NO. |
| in.   | mm   |                   |
| 12  | 300  | -                 |
| 14  | 350  | -                 |
| 16  | 400  | -                 |
| 18  | 450  | -                 |
| 20  | 500  | -                 |
| 24  | 600  | LAC375XJ24        |
| 26  | 650  | -                 |
| 30  | 750  | LAC375XJ30        |
| 36  | 900  | -                 |
| 42  | 1050 | LAC375XJ42        |
| 48  | 1200 | -                 |
| 60  | 1500 | -                 |

| 550 FASTENERS                                 |      |                   |
|---|------|-------------------|
| NC STEEL JOINT WITH NYLON COVERED STEEL CABLE |      |                   |
| BELT WIDTH                                    |      | WESTWARD PART NO. |
| in.   | mm   |                   |
| 18  | 450  | -                 |
| 20  | 500  | -                 |
| 24  | 600  | LAC550J24         |
| 26  | 650  | -                 |
| 30  | 750  | LAC550J30         |
| 36  | 900  | LAC550J36         |
| 42  | 1050 | -                 |
| 48  | 1200 | -                 |
| 54  | 1350 | -                 |
| 60  | 1500 | -                 |

**CALL FOR AVAILABILITY ON SIZES AND MATERIALS NOT SHOWN**

## FLEXCO® BOLT HINGED - HINGE PIN MATERIAL SELECTION

### SELECTION CHARTS



- AC BARE ARMORED CABLE**  
Heavy duty, long-wearing pin popular in underground mining applications. Armor wrapping protects interior wires.
- ACS BARE ARMORED STAINLESS CABLE**  
The same advantages as bare armored cable plus corrosion resistance.
- NAC NYLON COVERED ARMORED CABLE**  
Combines a durable armored steel wrap with a nylon covering for smooth operation and long service life. Nylon covering prevents pin migrations. Not recommended in wet, abrasive applications.
- NC NYLON COVERED STEEL CABLE**  
Nylon covering prevents pin migration. Not recommended in wet, abrasive applications.
- NCS NYLON COVERED STAINLESS CABLE**  
For greater corrosion resistance. Not recommended in wet, abrasive applications.
- SC BARE STEEL CABLE**  
Recommended for abrasive or gritty material conveyance.
- SSC BARE STAINLESS STEEL CABLE**  
For conditions where corrosion attacks steel pins.
- NB NYLON COVERED BRONZE CABLE**  
Fully non-magnetic hinge pin.

| NC (1/4" DIA.)<br>NYLON COVERED STEEL CABLE |      |                   |
|---|------|-------------------|
| BELT WIDTH                                  |      | WESTWARD PART NO. |
| in.   | mm   |                   |
| 24  | 600  | LACNC24-1         |
| 30  | 750  | LACNC30-1         |
| 36  | 900  | LACNC36-1         |
| 42  | 1050 | -                 |
| 48  | 1200 | LACNC48-1         |

| 300 SERIES - BARE STAINLESS CABLE (7/32 Dia.) |     |              |                   |             |          |
|---|-----|--------------|-------------------|-------------|----------|
| BELT WIDTH                                    |     | CLIIPPER NO. | WESTWARD PART NO. | DESCRIPTION | WT. LBS. |
| in.   | mm  |              |                   |             |          |
| 24  | 610 | SSC-24-1     | LACSSC-24-1       | Pkg. of 1   | 0.2      |

| 300 SERIES - STAINLESS SPRING WIRE (.141 Dia.) |      |              |                   |             |          |
|--|------|--------------|-------------------|-------------|----------|
| BELT WIDTH                                     |      | CLIIPPER NO. | WESTWARD PART NO. | DESCRIPTION | WT. LBS. |
| in.  | mm   |              |                   |             |          |
| 48   | 1219 | SS1-48       | LACSS1-48         | Pkg. of 10  | 1.9      |

### INSTALLATION TOOLS AND SUPPLIES

The only tools needed for Bolt Hinged fastener installation are the hand and power tools described here, and the Flexco Bolt Hinged Curved Templet.

| HAND INSTALLATION TOOLS |                     |                   |
|-------------------------|---------------------|-------------------|
| DESCRIPTION             | FOR FASTENER NUMBER | WESTWARD PART NO. |
| PUNCH                   | 375 x 550           | LCRP1P            |
| BORING BIT              | 375 x 550           | -                 |
| WRENCH                  | 375 x 550           | LCRS1S            |

| POWER INSTALLATION TOOLS |                     |                   |
|--------------------------|---------------------|-------------------|
| DESCRIPTION              | FOR FASTENER NUMBER | WESTWARD PART NO. |
| POWER PUNCH              | 375 x 550           | LCRHP1            |
| POEWR BORING BIT         | 375 x 550           | -                 |
| POWER WRENCH             | 375 x 550           | LCRH100* LCRHW1** |
| QUICK CHANGE CHUCK       | 375X & 550          | -                 |

\*For use with steel No. 375X or Steel No. 550 nuts.

\*\*For use with Stainless No. 375X or Stainles no. 550 nuts.



LCRS1S



LCRHP1



LCRH100



LCRHW1

**FLEXCO® SR™ SCALLOPED EDGE™ FASTENER SYSTEM**

**Lower fastener profile extends splice life and improves performance.**

The Flexco® SR™ Scalloped Edge™ fastener features a low profile that significantly reduces the fastener's exposure to cleaner blades, skirt rubber, and return idlers. Reduced wear and tear on the fastener extends the life of the splice to maximize belt availability and to help keep productivity on a roll.

Designed for rubber plied and PVC solid woven belting, and for worn belts unfit for vulcanized splices, the Flexco SR fastener features a patented scalloped Edge design. The scalloped design contributes to improved fastener profile resulting in increased compatibility with belt cleaners and improved cleaner-tip wear. The staggered rivet pattern also provides maximum holding ability by allowing the rivets to pass between the carcass fibers without damaging them.

A built-in viewport (see photo at right) simplifies fastener positioning. And self-setting rivets are installed from the top side of the belt for faster installation.

- Lower fastener profile extends belt splice life.
- Less effort required for installation.
- Reduces maintenance costs.
- Viewport assures proper installation alignment.





**How Flexco® SR™ Scalloped Edge™ Fasteners Work**

The SR (Self-Setting Rivet) fastener utilizes staggered pattern, multiple rivet attachments taht pass between carcass fibers without severing them. The specially shaped head of each pilot nail works in conjunction with the installation tool anvil plate to set the rivets. The same hammer blows that set the rivets also compress the fastener plates into the belt covers. This provides maximum holding ability and distributes splice tension evenly across the width of the belt.

## FLEXCO® SR™ SCALLOPED EDGE™ FASTENER SYSTEM

| FLEXCO® RIVET HINGED FASTENER SELECTION CHART |                                |                          |                      |           |   |      |  |      |
|---|--------------------------------|--------------------------|----------------------|-----------|---|------|--|------|
| Fastener Size                                 | FASTENER RATING                |                          | BELT THICKNESS RANGE |           | RECOMMENDED MIN. PULLEY DIAMETER                |      |  |      |
|   | For Belt Tension Rating Up To: | For Belt Strength Up To: | Measured After Skive |           | Operating Tension 75% - 100% Of Fastener Rating |      | Operating Tension Under 75% Of Fastener Rating |      |
|   | P.I.W.                         | KN/m                     | in.                  | mm        | in.   | mm   | in.  | mm   |
| R2  | 330                            | 60                       | 1/8 - 3/8            | 3 - 10    | 5   | 125  | 5  | 127  |
| R5  | 450                            | 79                       | 7/32 - 7/16          | 6 - 11    | 9   | 230  | 7  | 175  |
| R5 - 1/2                                      | 650                            | 114                      | 5/16 - 19/32         | 8 - 15    | 12  | 300  | 10   | 250  |
| R6  | 800                            | 140                      | 13/32 - 11/16        | 10.5 - 17 | 18  | 450  | 16   | 400  |
| RAR6LP  | 800                            | 140                      | 5/16 - 23/32         | 8 - 18    | 18  | 450  | 16   | 400  |
| R8  | 1500                           | 2630                     | 13/32-11/16          | 10.5-17   | 18  | 450  | 16   | 400  |
| R9  | 2000                           | 3500                     | 5/8-1                | 16-25.5   | 42  | 1050 | 42   | 1050 |

**R2**  Unique two teeth/two rivet combination offers highest efficiencies in strength and durability for medium duty applications.

**R5**  Ideal for applications such as wood processing or construction equipment with smaller pulleys as well as for underground mining.

**R5-1/2**  Midsize R5-1/2 is ideal as an upgrade for R5 or in applications where pulley size prohibits the use of R6.

**R6**  R6 can be used in certain applications for belt strengths up to 1200 P.I.W. (2100 kN/m) with R6 RustAlloy® and stainless steel rivets.

**R8**  Features lower fastener profile for improved compatibility with cleaner blades, skirt rubber and return idlers.

**R9** 



**FLEXCO® SR™ SCALLOPED EDGE™ FASTENER SYSTEM**

**RIVETS**

Rivets are available in either steel or stainless steel. Rivets are packaged 250 rivets per box. SRAA, SRA, SRB, SRB, and SRC rivets are also available in 100-count packages. Bulk packs of 2,000 rivets are also available in reusable plastic buckets.



| RIVET SELECTION CHART |                      |         |            |
|-----------------------|----------------------|---------|------------|
| FASTENER SIZE         | BELT THICKNESS RANGE |         | RIVET SIZE |
|                       | in.                  | mm      |            |
| R2                    | 1/8 - 7/32           | 3-6     | SRAA       |
|                       | 3/16 - 5/16          | 7-10    | SRAA       |
|                       | 9/32 - 3/8           | 7-10    | SRB        |
| R5                    | 7/32 - 5/16          | 6-8     | SRA        |
|                       | 9/32 - 3/8           | 7-10    | SRB        |
|                       | 11/32 - 7/16         | 9-11    | SRC        |
|                       | 13/32 - 7/16         | 10.5-11 | SRC/D      |
| R5-1/2 & RAR6LP       | 5/16 - 11/32         | 8-9     | SRB        |
|                       | 5/16 - 13/32         | 8-10.5  | SRC        |
|                       | 3/8 - 15/32          | 10-12   | SRC/D      |
|                       | 7/16 - 17/32         | 11-13.5 | SRD        |
|                       | 1/2 - 19/32          | 13-15   | SRE        |
|                       | 9/16 - 21/32         | 14-16.5 | SRF*       |
|                       | 5/8 - 23/32          | 16-18   | SRG*       |
| R6                    | 13/31 - 7/16         | 10.5-11 | SRC/D      |
|                       | 13/32 - 1/2          | 10.5-13 | SRD        |
|                       | 15/32 - 9/16         | 12-14   | SRE        |
|                       | 17/32 - 5/8          | 13.5-16 | SRF*       |
|                       | 19/32 - 11/16        | 15-17   | SRG        |
|                       | 13/32 - 1/2          | 10.5-13 | SRD        |

\*Applies to RAR6LP only.

| RIVETS                                      |             |           |
|---|-------------|-----------|
| SELF-SETTING PRE-ASSEMBLED WITH PILOT NAILS |             |           |
| WESTWARD PART NO.                           | DESCRIPTION | PKG. QTY. |
| LACSRA                                      | Steel rivet | Box 250   |

**SINGLE RIVET DRIVER TOOL**

| WESTWARD NO. | DESCRIPTION                         |
|--------------|-------------------------------------|
| LCRSR-50     | Single Rivet Driver Tool - Complete |



**R2 APPLICATOR TOOL**

| DESCRIPTION               | WESTWARD PART NO. | ITEM CODE |
|---------------------------|-------------------|-----------|
| R2T Applicator Tool - 12" | LCRR2T            | 40455     |



**FLEXCO® HINGED BELT FASTENERS**

| WESTWARD PART NUMBER | BELT WIDTH |     | BELT THICKNESS | DESCRIPTION                           | ITEM CODE |
|----------------------|------------|-----|----------------|---------------------------------------|-----------|
|                      | IN.        | MM  |                |                                       |           |
| LACR2-12             | 12         | 300 | 1/8 - 3/8      | Flexco Hinged Belt Fastener R2-12/30  | 41613     |
| LACR2-24             | 24         | 600 | 1/8 - 3/8      | Flexco Hinged Belt Fastener R2-24/60  | 41615     |
| LACR2-30             | 30         | 750 | 1/8 - 3/8      | Flexco Hinged Belt Fastener R2-30/750 | 41616     |
| LACR2-36             | 36         | 900 | 1/8 - 3/8      | Flexco Hinged Belt Fastener R2-36/900 | 41617     |



**FLEXCO® SR™ SCALLOPED EDGE™**

A wide selection makes it easy to match pins to the needs of the application. Selection ranges from bare steel cable to nylon-covered armored cable. Use the brief descriptions and the chart below to identify which hinge pins are available for each fastener type.

**HINGE PIN SELECTION CHART**

- AC BARE ARMORED CABLE**  
Heavy duty, long-wearing pin popular in underground mining applications. Armor wrapping protects interior wires.
- ACS BARE ARMORED STAINLESS CABLE**  
The same advantages as bare armored cable plus corrosion resistance.
- NAC NYLON COVERED ARMORED CABLE**  
Combines a durable armored steel wrap with a nylon covering for smooth operation and long service life. Nylon covering prevents pin migrations. Not recommended in wet, abrasive applications.
- NC NYLON COVERED STEEL CABLE**  
Nylon covering prevents pin migration. Not recommended in wet, abrasive applications.
- NCS NYLON COVERED STAINLESS CABLE**  
For greater corrosion resistance. Not recommended in wet, abrasive applications.
- SC BARE STEEL CABLE**  
Recommended for abrasive or gritty material conveyance.
- SSC BARE STAINLESS STEEL CABLE**  
For conditions where corrosion attacks steel pins.
- NB NYLON COVERED BRONZE CABLE**  
Fully non-magnetic hinge pin.

| <b>NYLON COVERED ARMORED HINGE PINS (1/4" Dia.)</b> |            |                          |                           |                    |
|---|------------|--------------------------|---------------------------|--------------------|
| <b>BELT WIDTH</b>                                   |            | <b>WESTWARD PART NO.</b> | <b>HINGE PIN DIAMETER</b> | <b>DESCRIPTION</b> |
| <b>in.</b>  | <b>mm.</b> |                          |                           |                    |
| 30  | 750        | LACNAC-30-1              | 1/4"                      | Pkg. of 1          |
| 36  | 900        | LACNAC-36-1              | 1/4"                      | Pkg. of 1          |
| 36  | 900        | LACNAC-36                | 1/4"                      | Pkg. of 10         |



**FLEXCO® BOLT SOLID PLATE FASTENER SYSTEM**

Flexco® Bolt Solid plate fasteners are engineered to meet the demands of the toughest material-handling applications. They can be applied to belts mechanically rated up to 620 PIW (105 kN/m), and are commonly used for highly abrasive materials such as sand, gravel and crushed stone, as well as coal, cement and salt.



**SUPERIOR STRENGTH**

Bolt Solid Plate fasteners provide a strong, sift-free splice with superior holding ability. The strength of this fastener is derived from the compression of the plates mounted above and below the belts, with high tensile strength bolts. The bolts compress top and bottom plates to distribute splice tension evenly across the entire width of each fastener plate. For added strength and pull-out resistance, specially formed teeth penetrate deep into the belt carcass - without damaging the carcass fibres.

**EASY INSTALLATION**

Specially designed templets, punches and boring tools make it easy to quickly and accurately punch holes into belts. Fasteners can then be installed on site using portable hand or power tools. The exclusive Flexco piloted bolt speeds installation. The piloted bolt tip cradles nuts securely in place, and simplifies installation by automatically aligning the bolt and nut thread.

No. 3, our largest, for belts 15/16" (24 mm) thick or more.

No. 1, our smallest, for belts from 3/16" (5 mm) to 7/16" (11 mm) thick.

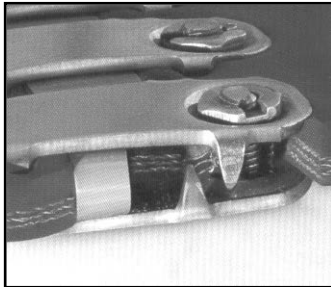

Plates feature specially designed teeth that penetrate deep into the belt carcass - without damaging carcass fibers. (left)



Flexco Solid Plate fasteners feature piloted bolts for faster installation. Piloted bolt tips cradle nuts securely in place. (right)

**90° SPLICE FOR STANDARD BULK CONVEYORS**

The conventional 90° splice is the most commonly used splice pattern for standard troughing and non-troughing bulk conveyors. It requires the fewest fasteners and is the easiest and quickest to install. Whenever pulley diameters allow, this is the preferred splice pattern.



**45° SPLICE FOR USE WITH SMALLER PULLEYS**

A 45° splice can be installed in situations where conveyor pulley diameters are as much as 25% smaller than the recommended size for 90° splices. This angled splice distributes tension over a greater belt area. The 45° splice passes more smoothly over pulleys and under cleaners. Cleaner blade life can be extended even more by skiving the 45° splice.

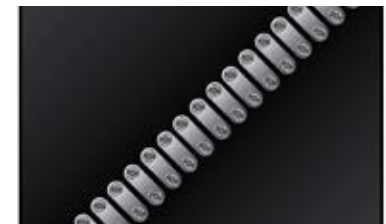

**RECESSED BOLT SOLID PLATE**

When belt top covers are 3/16" (4.8 mm) or more, we recommend countersinking (or recessing) fastener plates. Countersinking permits deeper penetration of fastener teeth into the carcass. This reduces plate exposure and extends splice life. Countersinking also contributes to reduced noise on return idlers. And because countersinking reduces the effective thickness.



## FLEXCO® BOLT SOLID PLATE FASTENER SYSTEM

### FASTENERS

|                                       |
|---------------------------------------|
| <b>"E" BOX<br/>(25 FASTENER SETS)</b> |
| WESTWARD PART NO.                     |
| STEEL                                 |
| LAC140E                               |
| LAC190E                               |



|   |
|---|
| <b>"C" BUCKET (100 FASTENER SETS -<br/>BOTTOM PLATES PRE-ASSEMBLED)</b> |
| WESTWARD PART NO.   |
| STEEL   |
| LAC140C   |
| LAC190C   |

| FASTENER SETS REQUIRED FOR A COMPLETE JOINT |      |                            |     |     |     |                                |     |     |     |                         |     |     |     |
|---|------|----------------------------|-----|-----|-----|--------------------------------|-----|-----|-----|-------------------------|-----|-----|-----|
| BOLT WIDTH                                  |      | FASTENER SIZE 1, 140 & 190 |     |     |     | FASTENER SIZE 1 1/2, 2 & 2 1/4 |     |     |     | FASTENER SIZE 2 1/2 & 3 |     |     |     |
|   |      | 90                         |     | 45  |     | 90                             |     | 45  |     | 90                      |     | 45  |     |
| in.   | mm.  | in.                        | mm. | in. | mm. | in.                            | mm. | in. | mm. | in.                     | mm. | in. | mm. |
| 12  | 300  | 10                         | 9   | 12  | 12  | 8                              | 8   | 9   | 10  | 6                       | 6   | 7   | 7   |
| 18  | 450  | 15                         | 14  | 19  | 19  | 12                             | 11  | 15  | 15  | 9                       | 9   | 12  | 12  |
| 24  | 600  | 20                         | 19  | 26  | 26  | 16                             | 15  | 21  | 21  | 13                      | 13  | 17  | 16  |
| 30  | 750  | 25                         | 24  | 33  | 33  | 20                             | 19  | 27  | 27  | 16                      | 16  | 21  | 21  |
| 36  | 900  | 30                         | 29  | 41  | 40  | 24                             | 23  | 33  | 32  | 19                      | 19  | 26  | 26  |
|   | 1000 |                            | 32  |     | 45  |                                | 26  |     | 36  |                         | 21  |     | 29  |
| 42  | 1050 | 35                         | 34  | 48  | 47  | 28                             | 27  | 39  | 38  | 22                      | 21  | 31  | 30  |
| 48  | 1200 | 40                         | 39  | 55  | 54  | 32                             | 31  | 44  | 43  | 26                      | 26  | 35  | 35  |
| 54  | 1350 | 45                         | 44  | 63  | 61  | 36                             | 35  | 48  | 49  | 29                      | 29  | 40  | 40  |
| 60  | 1500 | 50                         | 49  | 69  | 68  | 40                             | 39  | 56  | 55  | 32                      | 32  | 44  | 44  |
| 72  | 1800 | 60                         | 59  | 83  | 82  | 48                             | 47  | 68  | 65  | 39                      | 39  | 53  | 53  |

### BOLT SOLID PLATE INSTALLATION TOOLS

The only tools needed for Bolt Solid Plate fastener installation are a templet and portable hand or power tools such as wrenches and belt punches. Impact wrench driven power tools are recommended since they can speed installation time by at least 50%.

| BOLT BREAKER       |                       |              |
|--------------------|-----------------------|--------------|
| DESCRIPTION        | FOR FASTENER NO.      | WESTWARD NO. |
| Power punch        | 1, 140, 190 & RP1     | LCRHP1       |
| Power punch        | 1 1/2, 2, 2 1/4 & RP2 | -            |
| Power punch        | 2 1/2 & 3             | -            |
| Power boring bit   | 1, 140, 190 & RP1     | -            |
| Power boring bit   | 1 1/2, 2, 2 1/4 & PR2 | -            |
| Power boring bit   | 2 1/2 & 3             | -            |
| Power wrench       | 1, 140, 190 & RP1     | LCRHW1       |
| Power wrench       | 1 1/2, 2, 2 1/4 & RP2 | LCRHW2       |
| Power wrench       | 2 1/2 & 3             | -            |
| Quick change chuck |                       | -            |

| HAND INSTALLATION TOOLS |                       |              |
|-------------------------|-----------------------|--------------|
| DESCRIPTION             | FOR FASTENER NO.      | WESTWARD NO. |
| Bolt horn               |                       | -            |
| Punch                   | 1, 140, 190 & RP1     | LCRP1P       |
| Punch                   | 1 1/2, 2, 2 1/4 & P2P | -            |
| Punch                   | 2 1/2 & 3             | -            |
| Boring bit              | 1, 140, 190 & RP1     | -            |
| Boring bit              | 1 1/2, 2, 2 1/4 & RP2 | -            |
| Boring bit              | 2 1/2 & 3             | -            |
| Wrench                  | 1, 140, 190 & PR1     | LCRS1S       |
| Wrench                  | 1 1/2, 2, 2 1/4 & RP2 | -            |
| Wrench                  | 2 1/2 & 3             | -            |

## LACERS

A key advantage of the wire hook system is that the fasteners are machine-installed, yielding a precise, strong and smooth splice. Clipper® offers several different lacers to match a variety of on-site production or special application lacing needs. All lacers are designed with durability and speed-of-installation feature built into them.

## ROLLER LACING TECHNOLOGY™

The advantages of lacer installation and Roller Lacing Technology™ are what set Clipper wire hook systems apart from all other light-duty fasteners.

All three maintenance lacers - the Roller Lacer®, Microlacer® and Valulacer® - utilize Roller Lacing Technology.

Roller Lacing technology works fast to significantly minimize downtime, without sacrificing precision.

The top and bottom rollers are engineered to work with the Clipper proven hook design. They drive across the width of the splice, embedding each hook individually with clean penetration and consistency. The ability to control roller pressure assures the strongest possible splice with uniform hook clinch, easy pin insertion and extended life.

One person alone can install splices with Roller Lacing Technology, and it only takes a few steps to learn. The lacers are lightweight, streamlined and easy-to-carry. Sturdy aircraft aluminum construction handles rigorous use.

With Roller Lacer Technology at the core of our expertise, Clipper maintenance lacers clearly have more advantages.

- On-site installation.
- Simple operation that requires only one person - even with wide belts.
- Compatible with all hook sizes (except #25) by simply changing face strips.
- Continuous lacing feature allows the user to lace belts wider than the lacer width.



## ROLLER LACER FEATURES

### Face Strip Design:

Face Strips have been redesigned with a solid bottom layer. This 3-layer design eliminates the need for locking levers and back-up bars necessary with previous models. This has removed installation steps and improved the reliability of the lacer by eliminating two common wear items.

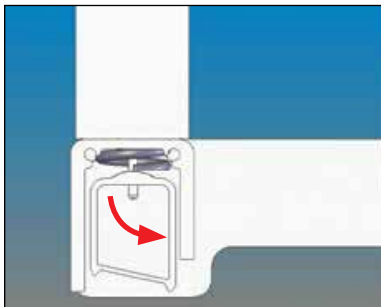

### Belt Clamp Design:

The inner clamp beam features a textured grip surface and when clamped it helps push the belt toward the Face Strip to allow proper hook reachback.

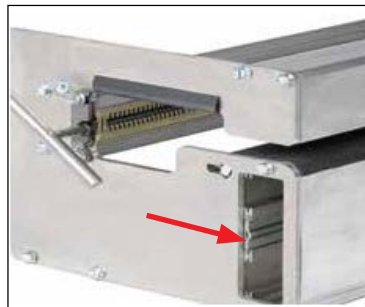

### Face Strip Storage:

Extruded slots in the lacer housing provide a secure

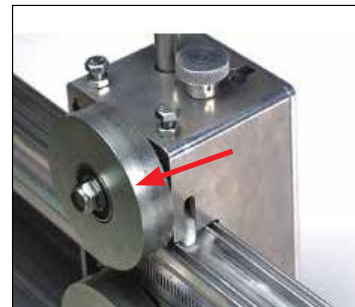

### Roller Shaft Diameter:

The larger diameter shaft provides the necessary support for the rollers to fully embed the hooks into the belt for a long-lasting splice.

## CLIPPER MAINTENANCE LACERS

### ROLLER LACER®

The Roller Lacer is the top-of-the-line model available in four widths: 24" (600 mm), 36" (900 mm), 48" (1200 mm) and 60" (1500 mm). Particularly well-suited for large operations with wide belts, its speed and ease-of-use are unmatched.

- Handle-actuated belt clamp system.
- Sturdy construction.
- Lightweight for on-site installation.
- Storage compartment for extra face strips & lacer pins.



### ROLLER LACER® (face strips sold separately)

| BELT WIDTH |      | CLIIPPER NO. | WESTWARD NO. | WT. LBS. |
|------------|------|--------------|--------------|----------|
| in.        | mm   |              |              |          |
| 24         | 600  | RL-24        | LCR03370     | 38       |
| 36         | 900  | RL-36        | LCR03371     | 47       |
| 48         | 1200 | RL-48        | -            | 55       |
| 60         | 1500 | RL-60        | -            | 63       |

### Guide Block Replacement Kit

(includes 4 guide blocks, 4 screws and installation tool for securing roller head for Roller Lacer®, Microlacer®, or Valuelacer®.)

| DESCRIPTION                 | WESTWARD NO. | WT. LBS. |
|-----------------------------|--------------|----------|
| Guide block replacement kit | LCR03433     | 1.00     |

### CLIPPER® FACE STRIPS (includes one lacer pin)

| BELT WIDTH                 |      | CLIIPPER NO. | WESTWARD NO. | WT. LBS. |
|----------------------------|------|--------------|--------------|----------|
| in.                        | mm   |              |              |          |
| Hook Size - 36, UCM36      |      |              |              |          |
| 24                         | 600  | FS36-24      | LCR04020     | 1.3      |
| 36                         | 900  | FS36-36      | LCR04019     | 2.3      |
| 48                         | 1200 | FS36-48      | -            | 1.1      |
| 60                         | 1500 | FS36-60      | -            | 1.2      |
| Hook Size - 1, UX-1        |      |              |              |          |
| 24                         | 600  | FS1-24       | -            | 0.6      |
| 36                         | 900  | FS1-36       | LCR03404     | 1        |
| 48                         | 1200 | FS1-48       | -            | 1.1      |
| 60                         | 1500 | FS1-60       | -            | 1.2      |
| Hook Size - 2-4, U2SP-U3   |      |              |              |          |
| 24                         | 600  | FS2-24       | -            | 0.6      |
| 36                         | 900  | FS2-36       | LCR04026     | 1.5      |
| 48                         | 1200 | FS2-48       | -            | 1.1      |
| 60                         | 1500 | FS2-60       | -            | 1.2      |
| Hook Size - 4 1/2-7, U4-U7 |      |              |              |          |
| 24                         | 600  | FS-1/2-24    | -            | 0.6      |
| 36                         | 900  | FS4-1/2-36   | LCR04031     | 1        |
| 48                         | 1200 | FS4-1/2-48   | -            | 1.1      |
| 60                         | 1500 | FS4-1/2-60   | -            | 1.2      |

### CLIPPER® REPLACEMENT LACER PINS

| BELT WIDTH          |      | CLIIPPER NO. | WESTWARD NO. | PIN DIAMETER |
|---------------------|------|--------------|--------------|--------------|
| in.                 | mm   |              |              |              |
| Hook Size - 1 or 36 |      |              |              |              |
| 24                  | 600  | LP1/36-24    | -            | 0.067        |
| 36                  | 900  | LP1/33-36    | -            | 0.067        |
| 48                  | 1200 | LP1/36-48    | -            | 0.067        |
| 60                  | 1500 | FS36-60      | -            | 0.067        |
| Hook Size - 2 - 7   |      |              |              |              |
| 24                  | 600  | LPREG24      | -            | 0.106        |
| 36                  | 900  | LPREG36      | -            | 0.106        |
| 48                  | 1200 | LPREG48      | -            | 0.106        |
| 60                  | 1500 | LPREG60      | -            | 0.106        |

### LACER PINS FOR MANUAL ROLLER LACER®

| BELT WIDTH          |     | CLIIPPER NO. | WESTWARD NO. | WT. LBS. |
|---------------------|-----|--------------|--------------|----------|
| in.                 | mm  |              |              |          |
| Hook Size - 1 or 36 |     |              |              |          |
| 24                  | 600 | LPMAN1/36-24 | LCR03997     | 0.4      |
| 36                  | 900 | LPMAN1/36-36 | LCR03998     | 0.5      |

## CLIPPER MAINTENANCE LACERS

### MICROLACER®

The Microlacer® is best for belts 14" (350 mm) wide and less, or wider belts with infrequent lacing requirements.

- Belts are secured by tightening belt clamp knobs.
- Sturdy construction.
- Compact and lightweight.
- Economical for use with wide belts and infrequent lacing needs.



### MICROLACER® (face strips sold separately)

| BELT |     | CLIPPER NO. | WESTWARD NO. | WT. LBS. |
|------|-----|-------------|--------------|----------|
| in.  | mm  |             |              |          |
| 14   | 350 | Microlacer  | LCR03368     | 27.0     |

*Note: Includes carding paper remover and scissors.*

### CLIPPER® FACE STRIPS (includes one lacer pin)

| HOOK SIZE       | CLIPPER NO.   | WESTWARD NO. | WT. LBS. |
|-----------------|---------------|--------------|----------|
| 36, UCM36       | FSC36-MICRO   | -            | 0.4      |
| 1, UX-1         | FS1-MICRO     | -            | 0.4      |
| 2-4, U2-U3      | FS2-MICRO     | -            | 0.4      |
| 4 1/2-7, U4, U7 | FS4-1/2-MICRO | -            | 0.4      |

### CLIPPER® REPLACEMENT GAUGE PINS

| HOOK SIZE | CLIPPER NO.  | WESTWARD NO. | WT. LBS. |
|-----------|--------------|--------------|----------|
| 1/36      | LP1/36 MICRO | -            | 0.67     |
| 2-7       | LPREG MICRO  | -            | 0.106    |

## BALER BELT LACER™

### THE LACING TOOL MADE EXCLUSIVELY FOR BALER BELTS.

The Baler Belt Lacer was designed to give dealers and farmers a way to get OEM-quality splices in baler belts easily and quickly, because an idle baler can mean lost time, money and hay quality.

Built of heavy-gauge steel, the Baler Belt Lacer is still light enough for one person to carry and use anywhere - in the shop or out in the field.

And it produces a perfect splice every time, all the time.



### The PowerLever™ does all the work.

The key to the Baler Belt lacer is the PowerLever, a feature designed to produce the exact amount of force required to properly embed the hooks in one easy motion.

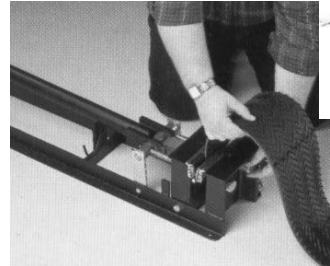

(1) Adjust jaw setting to belt thickness

### Adjustable to a full range of thicknesses.

The Baler Belt lacer's precisely machined and positioned jaws can be manually adjusted to allow for optimum hook clinch in any baler belt. Available in two models: 7" and 10". Both can continuously lace any width baler belt.

### Perfect splices every time.

The Baler Belt Lacer's large diameter pin forms the optimum hook loop profile so that the hook legs are exactly parallel with the cover of the belt. This feature is combined with a precise jaw angle, built-in pressure plates and the controlled force of the PowerLever to assure perfect clinch, and the strongest, longest lasting splice for any baler belt width and thickness.

The lacer works with the following Clipper Baler Belt Hook sizes:

- #4 1/2-3 RHTX
- #4 1/2-4 RHTX and
- #4 1/2 RHTX

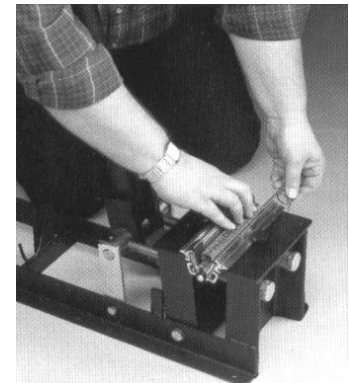

(2) Load hooks and insert pin

For perfect splices on your baler belts, get the tool made for baler belt lacing ...only from Clipper.

### BALER BELT LACER® (laces all Clipper baler hooks)

| HOOK SIZE | CLIPPER NO. | WESTWARD NO. | WT. LBS. |
|-----------|-------------|--------------|----------|
| 7         | 175         | LCR03434     | 51.0     |
| 10        | 250         | LCR03435     | 51.0     |

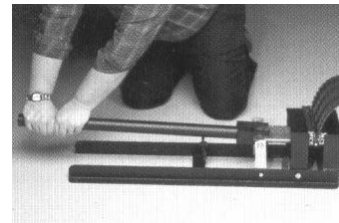

(3) Use PowerLever to imbed hooks

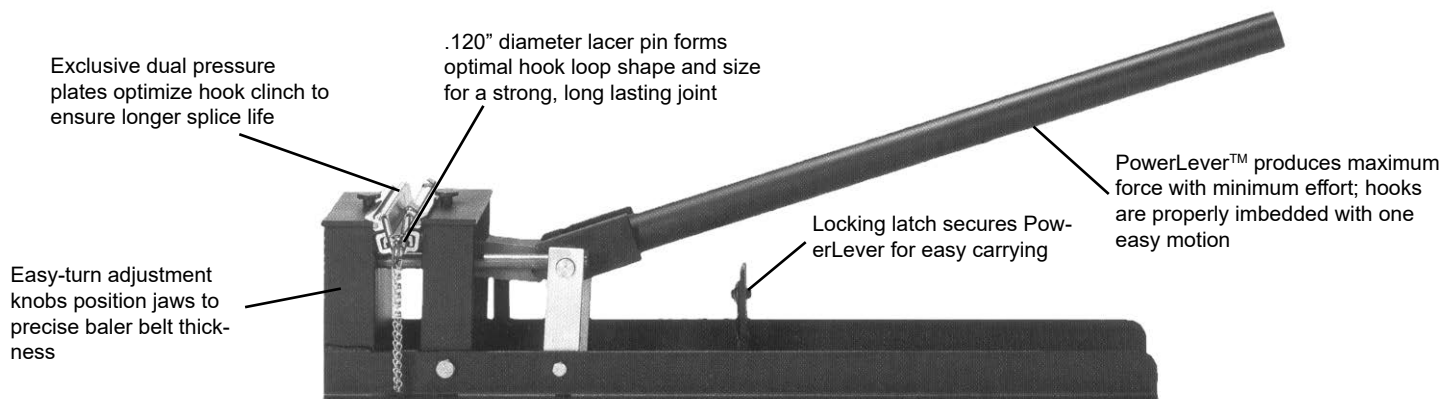



**INSTALLATION TOOLS**

**ALLIGATOR RIVET - COMPLETE TOOL KITS**

Each kit includes an installation tool, belt hand skiver, 1 lb. hammer, pin bender and 2 packages of Alligator rivets. Packaged in durable plastic tool box.

| DESCRIPTION                    | WESTWARD PART NO. | ITEM CODE | WT. LBS. |
|--------------------------------|-------------------|-----------|----------|
| 7" (175 mm) installation tool  | LCRARTK-7         | 15006     | 14.5     |
| 14" (350 mm) installation tool | LCRARTK-14        | 15015     | 18.5     |



**ALLIGATOR RIVET APPLICATOR TOOLS**

| DESCRIPTION                    | WESTWARD PART NO. | ITEM CODE |
|--------------------------------|-------------------|-----------|
| 7" (175 mm) installation tool  | LCRART-7          | 15004     |
| 14" (350 mm) installation tool | LCRART-14         | 15005     |

**READY SET STAPLE FASTENER - R187 TOOLS**

The RSC187 tool accurately installs two staples simultaneously for quick, dependable splice installation. No. RS62, No. RS125 and No. RS187 fasteners are each installed with the Series RSC187 tool. Tools come complete with guide blocks and driver. RSC187 tools are available in a variety of sizes which allow varying amounts of belt width to be laced at one position. Tools can be moved rapidly along the belt as staples are installed. Tools up to 12" wide, speed splicing. Wider tools are available for production lacing and fabrication shop requirements.

| WESTWARD PART NO. | ITEM CODE |
|-------------------|-----------|
| LCRRSC187-2       | 54626     |
| LCRRSC187-4       | 54627     |
| LCRRSC187-6       | 54628     |
| LCRRSC187-12      | 54629     |
| LCRRSC187-24      | 54631     |



**READY SET STAPLE FASTENER - R187 COMPLETE STAPLE KIT**

Everything you need to install, maintain and repair No. RS62, No. RS125 and No. RS187 Alligator staple belt splices. Lightweight, only 16 1/2 lbs. Kit includes a RSC187 installation tool, staple set plate, hand skiver, belt marker, belt nippers and a 1 lb. hammer. All packaged in a durable metal box with plenty of room left over for other items.

| WESTWARD PART NO. | ITEM CODE | DESCRIPTION         |
|-------------------|-----------|---------------------|
| LCRRSTK4-6        | 54634     | 6" Installation Kit |



**SINGLE RIVET DRIVER TOOL**

| WESTWARD NO. | DESCRIPTION  |
|--------------|--|
| LCRSR-50     | Single Rivet Driver Tool for Flexco® SR™ Scalloped Edge™ Fastener System |



**R2 APPLICATOR TOOL - 12"**

| WESTWARD NO. | ITEM CODE | DESCRIPTION  |
|--------------|-----------|--|
| LCRR2T       | 40455     | 12" R2 Applicator Tool for for Flexco® SR™ Scalloped Edge™ Fastener System |



## INSTALLATION TOOLS

### MATO (Heavy Plate) "U" TOOLS

| PART NUMBER  | DESCRIPTION                                       |
|--------------|---|
| LAC411295807 | MATO Hex Shank Punch for Air Hammer               |
| LAC411295825 | Hand Punch  |
| LAC411295827 | 18mm Belt Skiver                                  |
| LCR411295869 | 07 U20 Prof-14 Used for 7" John Deere Baler Belts |
| LCR411295828 | Replacement Blades for Belt Skiver (5/pkg)        |

### MATO (Heavy Plate) "H" TOOLS

| PARTNUMBER   | DESCRIPTION   |
|--------------|---|
| LCR411296961 | 7" H24 Profi Installation Field Tool Continuous Lacing Capabilities Wider than 7" |
| LAC411296963 | 7" H24 Eco Field Tool   |

### TITAN STYLE INSTALLATION TOOL

| WESTWARD NO. | DESCRIPTION               |
|--------------|---------------------------|
| LAC109201    | 7" Vice Installation Tool |

## CLIPPER® SPECIALTY LACERS

### WISE LACERS

The reliable Wise Lacer is the most economical method of installing Clipper® hooks.

- Fits into any shop vise.
- Ideal for the user with few belts.
- Continuous lacing feature.

| HOOK SIZE  | CLIPPER NO. | WESTWARD NO. | WT. LBS. |
|------------|-------------|--------------|----------|
| 2-7, U2-U7 | R-4         | LCR03018     | 1.0      |
| 2-7, U2-U5 | R-7         | LCR03019     | 2.0      |
| 2-7, U2-U5 | R-10        | LCR03020     | 3.0      |
| UCM36      | 36VL-7      | LCR03238     | 3.0      |

| WESTWARD NO. | DESCRIPTION |
|--------------|-------------|
| LCR03022     | R-7 Spring  |

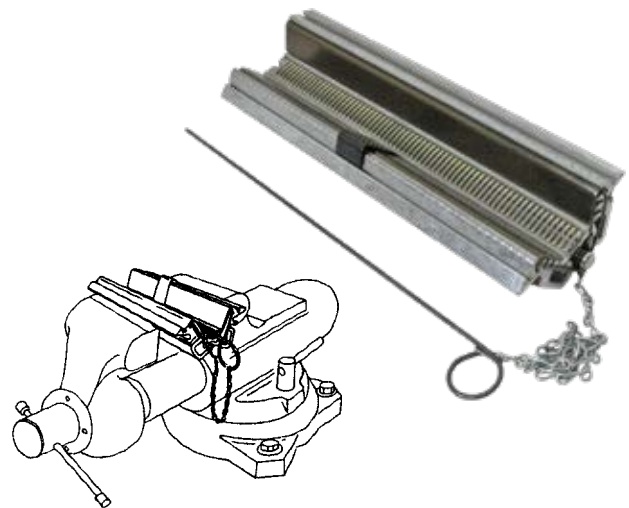

## ACCESSORIES

### 14" BELT CUTTER

The 14" Belt Cutter is an efficient tool that cuts belts quickly and easily.

- Table support has a built-in square, ensuring a proper cut.
- Belts can be cut in the middle of the roll by opening the end of the cutter.
- Cuts belts up to 3/8" (9.5 mm) thick.
- For belts up to 14" wide (350 mm).

| CUTTER WIDTH |     | CLIPPER NO. | WESTWARD PART NO. |
|--------------|-----|-------------|-------------------|
| in.          | mm. |             |                   |
| 14           | 350 | Cutter - 14 | LCR03230          |



| PART NO. | DESCRIPTION                                  |
|----------|--|
| LCR03009 | 10" (250 mm) Rreplacement Blade for LCR03230 |
| LCR03010 | 10" (250 mm) Rreplacement Nylon Block        |
| LCR03450 | 14" (350 mm) Rreplacement Blade              |

### BELT SKIVER - complete with blade

- \* Width of Skive 2-1/2" (64 mm).
- \* Comes with standard blade.
- For belt thickness 1/4" to 1-1/4"
- \* Skive depth 1/16" - 3/8"
- \* Weight: 20.7 lb.

| WESTWARD NO. | DESCRIPTION                       |
|--------------|-----------------------------------|
| LCRFSK2      | Belt Skiver - Complete with Blade |



### ROUGH TOP BELT SKIVER

- Efficiently removes impression covers from the belt prior to fastener size selection and installation.
- Hand-held.

| WESTWARD NO. | DESCRIPTION           |
|--------------|-----------------------|
| LCRRTVS      | RTBS Rough-Top Skiver |



### UNIBAR® CUTTER

- Used to cut Unibar® strips to shorter lengths.
- Hand-held.

| DESCRIPTION        | WESTWARD PART NO. |
|--------------------|-------------------|
| Cutter-Unibar Wire | LCR03445          |

